

ANR-957

Caged Fish



Production In Alabama

Aquaculture has expanded rapidly since the 1980s. Worldwide aquaculture accounts for more than 15 percent of all seafood production. In the United States, aquaculture—particularly catfish production—was one of the few bright spots in U.S. agriculture in the 1980s and is continuing expansion in the mid-1990s.

Many land owners who are interested in aquaculture may not have the financial and physical resources or the practical experience to start a large-scale aquaculture enterprise. Growing fish in cages can be a means for landowners with existing ponds to produce fish for supplemental income and to gain experience in aquaculture. Cage culture is an intensive form of aquaculture that has its own particular set of advantages and problems. The advantages and disadvantages of cage production should be considered carefully by perspective producers before making an investment.

The advantages of cage culture include the following:

- Many water resources can potentially be used, including ponds, lakes, strip pits, rivers, and streams.
- Cage culture requires a relatively small financial investment.

- Feeding, sampling, observation, and the harvesting process are comparatively simple.

- The pond or water resource can still be used for other farming activities and for other types of recreation such as sport fishing.

Cage culture also has particular disadvantages because of the intense crowding and confinement of the fish, including the following.

- There is a relatively high incidence of disease, and the disease spreads rapidly in cages.
- There is localized poor water quality, such as low dissolved oxygen, in and around cages.
- Caged fish need a nutritionally complete, fresh feed.
- Cages are attractive to predators, vandals, and poachers.

The potential to lose fish to disease, low dissolved oxygen, poor nutrition, and poaching should not be discounted. Fish can be produced profitably in cages, but these problems should be anticipated, and methods to manage each problem need to be examined.

Alabama growers produce more warm-water fish in cages than any other state. Since the late 1980s the cage culture of catfish and tilapia has expanded to be a viable alternative

enterprise and a supplemental source of income for many Alabama pond owners. The growth of the cage industry throughout the Southeast has led to expanded cage research at Auburn University and other southern universities. This publication was designed to educate potential producers on the resources, equipment, marketing, and management skills needed to update existing producers on the latest research results that impact cage production and profitability.

Cage Construction

Numerous methods and materials can be used in building cages. The construction material must be strong and durable enough to hold the collective weight of the fish. The mesh size used must allow for good water exchange and still contain the smallest fish to be stocked. One-half-inch diameter mesh is the standard. It is small enough to hold a minimum size fingerling (one that will reach market size in one growing season) and large enough for adequate water exchange.

There are two basic types of cages: hard or rigid cages and soft or net cages. Hard cages are usually constructed of vinyl-coated welded wire or extruded plastic mesh. Soft cages are constructed of polypropylene or nylon netting. Each type of cage has its own advantages and disadvantages. The main advantage of a hard cage is predator exclusion. The rigid cage prevents large pond fish from disturbing the caged fish and excludes predators such as turtles, otters, and birds from the cage. The primary disadvantage of a hard cage is that it is more difficult to maneuver, harvest, transport, and store.

Soft cages are easy to transport and harvest while still maintaining a moderate level of predator exclusion. However, if there are large catfish (5 pounds or larger) loose in the pond,

they may harass the caged fish at feeding times. This large-fish assault is stressful to fish in the cage. Predators such as minks, otters, and snapping turtles may be able to chew through soft cages. Soft cages are currently the most popular for “commercial” cage production in ponds where predators are not serious problems.

Cage Designs

Components of cage design include a frame, mesh or netting, a feed ring (to keep feed in cage), a lid or cover (to exclude animal and human predators), and some type of flotation device. Cage size and shape are not critical but should be at least 4-foot deep and meet the requirements listed above. The most popular cage designs are square or rectangular and the most common cage sizes are 4 x 4 x 4 feet, 4 x 8 x 4 feet, 6 x 6 x 4 feet, and 6 x 12 x 4 feet. Flotation devices for cages may be a PVC pipe collar, styrofoam blocks, and empty plastic jugs. A 3- or 4-inch PVC sealed pipe collar is used most commonly. This collar provides uniform flotation. The flotation collar should be attached to the sides of the cage so that the top of the cage is 2 to 4 inches out of the water to prevent fish escapement if the top is open. Some people fill the pipe with styrofoam or other flotation material in case the glue seals leak and the pipe takes on water.

Rigid cages of welded wire do not require a frame. Extruded plastic mesh is stiff but may need a frame to give the cage shape and support. One 4- x 50-foot roll of 1/2-inch mesh welded wire or extruded plastic mesh



Rigid cages

Drawing of typical soft mesh cage with lid and feeding ring.

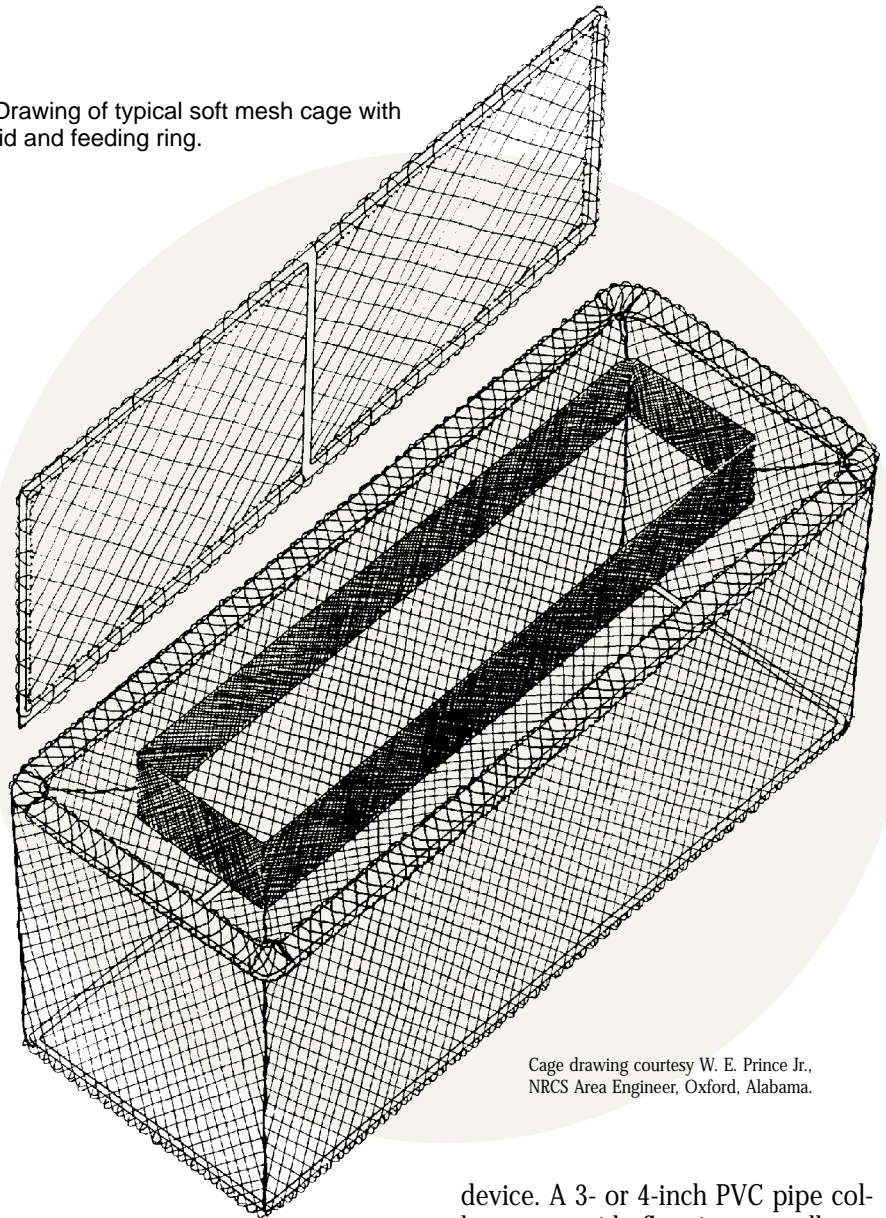

Cage drawing courtesy W. E. Prince Jr.,
NRCS Area Engineer, Oxford, Alabama.

will make two 4 x 4 x 4 foot cages or one 4 x 8 x 4 cage. This material can be shaped by hand and cut with tin snips. Form the cage into a square or rectangle. Fasten the seams using stainless steel hog rings or lace them together with 18-gauge bell wire (plastic coated solid copper wire) or stainless steel wire. There should be no gaps along the seams or fish may escape. Attach the bottom the same way. The top can be secured along one edge so that it can be easily opened or it can be attached all the way around.

Some net companies manufacture soft cages. These can be purchased ready to use, except for the flotation

device. A 3- or 4-inch PVC pipe collar can provide flotation as well as an upper frame. Many soft cages have a sleeve around the top edge into which the pipe will fit. A smaller, 1-inch diameter perforated pipe (perforated so it will sink) can be used to give shape to the bottom of the soft cage. Some producers and manufacturers place lead weights along the bottom seams of the cage.

Soft-cage manufacturers commonly build a top that is made of a larger mesh netting measuring 1 x 1 inch to 2 x 2 inches, supported by a 1-inch PVC pipe frame that fits over the flotation collar. This top may be attached to the support frame using black plastic cable ties (white ties will deteriorate in sunlight) or wire. A list of companies that supply cages

and cage building materials is available at your county Extension office or from an Extension Fisheries Specialist.

Feed-retaining rings should be used in all cages to keep the floating feed in the cage. A rectangle of 1/4- or 1/8-inch plastic mesh can be suspended from the inside cage corners for this purpose or can be floated by a 3/4- or 1-inch PVC or polypropylene tubing frame. The feed ring should be 12 inches deep with 2 to 3 inches above the water.

Species Selection And Stocking Rates

Many species of fish can be produced in cages. Species that have been researched and successfully produced by private individuals in the Southeast include catfish, trout, tilapia, hybrid striped bass, red drum, and several species of carp. Research findings and market trends show that catfish, tilapia, trout, and hybrid striped bass have potential for successful production and marketing in Alabama and throughout much of the Southeast.

Fish are stocked into cages at high densities. Only at high densities is cage production profitable. High densities also reduce aggressive behavior of fish toward each other. Stocking fish in cages at lower than recommended densities, particularly catfish, can cause fighting among fish that may lead to stress, disease, and mortalities. Stocking fish of different sizes in the same cage enables large fish to dominate smaller fish (see Stocking



Caged fish are held at extremely high densities. Example shows catfish at seven per cubic foot.

and Handling). Large-fish dominance reduces the growth of smaller fish and can lead to disease and mortalities.

Fish are stocked based on the cage volume. Table 1 gives the recommended stocking rates (per cubic foot) and approximate stocking dates for caged fish in Alabama. Fish can be stocked into cages at slightly higher densities than those recommended (10 to 15 percent). The densities recommended should produce fish of 3/4 pound to 1 1/2 pounds from a 6-inch fingerling in one growing season. Experience suggests that stocking at higher densities results in smaller fish while low densities tend to produce larger fish.

Catfish, tilapia, and hybrid striped bass will take from 4 to 8 warm months to reach market size, depending on fingerling size, time of stocking, weather conditions, feeding rates, and water quality. Everything being equal, the larger the fingerling stocked, the shorter the time to reach market size. Tilapia are a tropical fish and must have water temperatures above 60°F to survive and above 70°F to grow. Therefore, tilapia should not be stocked before the water temperature is above 60°F and must be harvested in the fall before the water temperature falls below 55°F.

Rainbow trout can be produced during the winter in Alabama, from late October through April or early May. Trout should not be stocked in the fall until the water temperature is near 60°F and must be harvested before the water reaches 70°F in the spring. Large fingerlings (more than 7 inches) must be purchased or trout will not reach market size during Alabama's relatively short winter.

Research suggests that there is a difference in production characteristics for different strains of fish grown in cages. In other words, not all fish adapt, grow, and survive well in cages even though they may grow well in open ponds. Research at Auburn University has shown that catfish from different public and private hatcheries may adapt to cages with varying degrees of success. In general, catfish of Kansas, Marion, or Auburn-select strain ancestry grow well in cages. Other strains also may grow well. Ask other successful cage producers where they get their fingerlings for stocking. Ask hatchery owners if their fish grow well in cages. It is not advisable to purchase fingerlings from hatcheries with unknown strains or those which have not demonstrated, through the experience of cage producers, that they grow well in cages.

Table 1. Recommended Stocking Rates And Suggested Stocking Times For Cages.

Species	Stocking Rate (number per ft. ³)	Stocking Time (month)	Cage Size/Number {cages 4 ft. deep}
Catfish	5 to 9	February -June	4 x 4 = 320-575
			4 x 8 = 640-1150
			6 x 6 = 720-1300
			6 x 12 = 1440-2600
Tilapia	5 to 12	May-July	4 x 4 = 320-510
			4 x 8 = 640-1540
			6 x 6 = 720-1730
			6 x 12 = 1440-3460
Hybrid Striped Bass	5 to 8	February-May	4 x 4 = 320-510
			4 x 8 = 640-1020
			6 x 6 = 720-1150
			6 x 12 = 1440-2300
Rainbow Trout	5 to 12	October-November	4 x 6 = 320-770
			4 x 8 = 640-1540
			6 x 6 = 720-1730
			6 x 12 = 1440-3460



Stocking fingerlings in early spring.

Stocking And Handling Fish

There are a number of preparations to be made prior to stocking in order to maximize growth and efficiency. Planning and preparation help reduce problems later on.

Cage Preparation. It is important to keep empty cages in the water to reduce wear. Cages left on the bank are subject to damage by mice and rats, which are attracted by fish odors. Sunlight also contributes to the breakdown of netting. Check empty cages (even new ones) for holes, weak mesh, cracks in the PVC pipe, loose seams, turtles, and wild fish. If your soft cage has any holes, it is a good idea to patch the holes using coated net twine or black plastic cable ties. Net repair twine (seine twine) can be obtained from net manufacturers. Twine sizes of 15, 18, and 21 are recommended for net repair.

Pond Preparation. If you have trash fish (for example, green sunfish) in your pond, winter is a good

time to partially or completely drain the pond and remove these fish. Complete draining and treating any left over puddles with rotenone or hydrated lime will usually control this problem. Remember, if you treat with rotenone in the winter it will remain active several weeks to months and fish should be stocked only after it has detoxified. While the water is down in the pond is also the time to make any necessary repairs to the dock or pier and drain structure.

Stocking. The best time to stock fingerlings is when water temperatures are below 60°F. Water in much of Alabama usually remains below 60°F until mid-March. Handling fish at any time of the year is stressful, but at lower water temperatures less stress is placed on the fish. Fish transported or stocked at water temperatures below 60°F would likely result in few stress-related mortalities or disease. Avoid stocking when water temperatures are between 70° and 80°F, as this is the range where disease outbreaks are most prevalent and where the risk of direct mortality and disease is greatest.

For best results, it is important to stock **healthy, size-graded fish**. Indicators of good fish health are uniformity of skin color between fish and the absence of sores, blotches, spots, or frayed fins. An indicator of fish health is that a healthy fish will vigorously avoid being captured and will dart or swim rapidly away when approached.

Closely graded fish will reduce

dominance by larger or more aggressive fingerlings. Grading fish also decreases the size variability of the fish at harvest, ensuring that the maximum number will reach market size. Research has shown that closely graded fish can increase production by as much as 25 percent (Figure 1). Fingerlings should be examined prior to stocking to see that they have been closely graded. If fingerlings are not all about the same size, and several cages are to be stocked, the producer should grade the fingerlings and stock different sizes into separate cages.

There are several advantages to stocking fingerlings larger than 6 inches. Fingerlings 7- to 9-inches long will require less time to reach market size. Larger fingerlings also have a more developed immune system, making them more resistant to disease.

Fingerling Sources And Transportation. Fingerlings are available from many sources. Contact your county Extension office or Fisheries Specialist for a list of fingerling suppliers. If you are interested in obtaining large fingerlings, contact the fingerling producers early as they do not always have adequate supplies of large fingerlings and most operate on a first-come, first-served basis.

The safest method to get the fingerlings to your pond in good condition is to work with an experienced hauler. Fingerlings may be hauled long distances with the proper equipment and care. If you are interested in hauling fingerlings yourself, information on hauling procedures, equipment, and loading rates can be found in Southern Regional Aquaculture Center publications (SRAC No. 390, No. 392, and 393).

Acclimation. Water temperatures and pH between the hauling tank water and the pond should be checked before the fish are stocked. If water temperature differs by more than 5°F or pH by more than 2 units, water should be slowly exchanged between the pond and the hauling

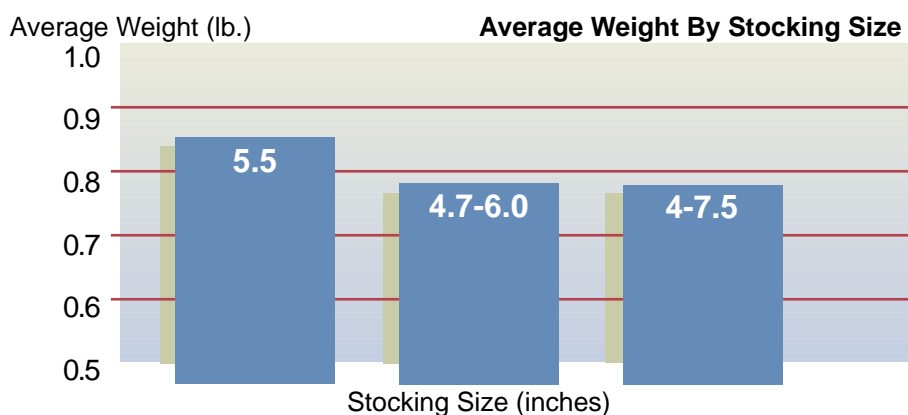

Figure 1. Closely graded catfish fingerlings show superior growth rates.



Cages should be placed for maximum water circulation.

tank to “acclimate” the fish to the new water conditions. Acclimation of a 5°F or 2 unit pH change can be done by slowly exchanging enough water to effect the change over a period of 30 minutes or more.

Once the fingerlings are acclimated, they should be transported as quickly and as gently as possible to the cage. Dipping the fingerlings from the tank (instead of draining the hauling tank into a basket) and transporting them to the cages in batches weighing less than 10 pounds will reduce stress and injury. After the cage is stocked many producers add live-stock-feed-grade salt or rock salt to the cage at a rate of 0.15 pound per cubic foot (2,500 parts per million) to help reduce handling stress.

Cage Placement And Water Quality

Ponds for cage culture should be ½ acre or larger. Larger ponds generally have fewer water quality problems than small ponds. The size of the pond determines how many fish can be produced in cages. No more than 2,000 pounds of fish can be produced in cages per surface acre of pond without a means of mechanical aeration. Aeration makes it possible to produce up to 3,000 pounds of fish per acre in cages. Cage production is intensive aquaculture, but production on a per acre basis is less than open pond culture.

Cages must be placed where natural currents in the pond will move water through the cage. **Circulation of water through the cage is vital.**

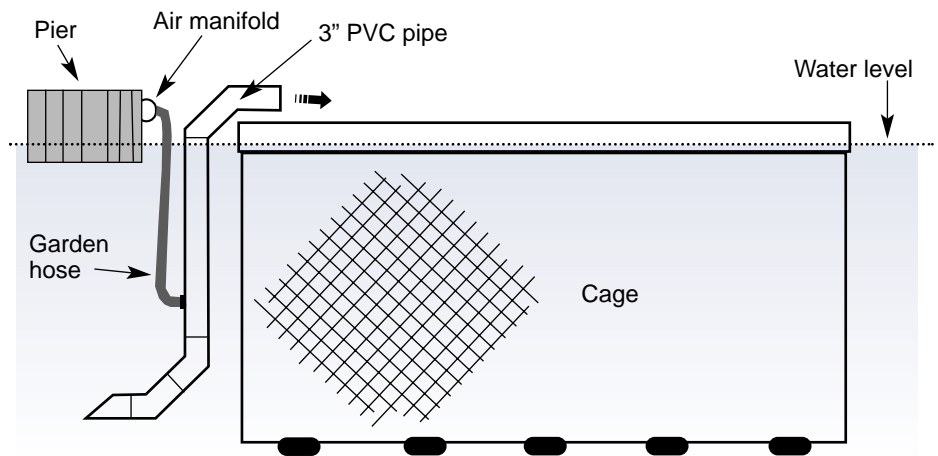

Figure 2. Side view of cage with mounted air-lifts.



Air-lifts running on cage.

Dissolved oxygen must be brought into the cage, and wastes must be flushed from the cage if the fish are to survive and grow. Wind action causes water movement. Cages should be placed so that the prevailing winds of summer blow across or through them. Place cages at least 10 feet or more apart. Good water depth under the cage keeps fish wastes from building up to foul the water quality within the cage. Water depth under the cage should be a minimum of 1 foot and preferably 2 feet or more. Finally, do not place cages in areas with submerged aquatic vegetation. Aquatic vegetation can severely reduce water circulation through the cage.

Good water quality is important in any type of aquaculture but particularly significant in cage culture because of the confinement and density of the fish. Water quality in the pond can be acceptable while the immedi-

ate area around the cage may have poor quality water. Fish, bacterial, and algal respiration in and around the cage can cause low dissolved oxygen (D.O.) and high ammonia that can stress or kill the fish. Good water quality can only be maintained through correct cage placement, proper stocking and feeding practices, or by providing mechanical aeration to add D.O. and move water through the cage.

Aeration. Aeration can enhance water quality, reduce stress, improve feed conversion efficiency, and increase growth rates. Research has shown that aeration can improve cage production by 20 percent or more. Aeration is most commonly needed at night or during still, overcast days. Aeration for cages can be provided by several types of mechanical aerators. The key to aeration is to create a current that moves water through the cage. Mechanical aera-

tors like paddlewheels, vertical pumps, or propeller-aspirators can be placed near cages where they create currents. These types of aerators work well to aerate cages placed near them and within their current pattern. However, they may not work well in creating currents that aerate multiple cages, particularly cages staggered along both sides of a pier.

Air-lift pumps powered by high-volume, low-pressure regenerative blowers can be a very efficient and cost effective means of aerating many cages spaced along a pier. Placing air stones directly in cages appears to agitate and stress catfish, while aerated water pouring into the cage from air-lifts at the surface does not disturb them. Figure 2 shows how air-lifts can be constructed from a 3-inch PVC pipe and connected by $\frac{5}{8}$ -inch garden hose to a 2-inch or larger air supply manifold attached to the pier. Each 3-inch air-lift will move approximately 60 gallons per minute into the cage. One air-lift is usually sufficient to aerate one small cage (4 x 4 x 6 feet or 6 x 6 feet), but two air-lifts should be used on larger cages (6 x 12 feet). As many as 25 air-lifts can be powered from one, 1-horsepower regenerative blower. Air-lifts will not lift water more than a few inches above the pond's surface and therefore should be attached to the cage as close to the water surface as possible. **All air-lifts must be attached to the cage at the same level and kept straight vertically, not tilted.**

Nitrogen Wastes. Ammonia and nitrite are toxic to fish. These compounds come from the digestion of feed and the decomposition of organic matter (fish wastes, uneaten feed, and dead plant material) in the pond. Toxic concentrations of ammonia and nitrite can build up in ponds that are overfed, that receive excessive livestock wastes in runoff water, or that experience an aquatic plant or phytoplankton (microscopic algae) die-off. Checking ammonia and nitrite concentrations weekly can help producers anticipate water quality changes or trends. These tests should

also be conducted whenever the color of the pond's water changes rapidly.

Most ponds in Alabama are acidic. Adding finely ground agricultural limestone to acidic ponds increases their alkalinity, which helps stabilize phytoplankton blooms and buffers pH changes that can help reduce the toxicity of ammonia. Cage production should not begin in ponds with alkalinities below 20 mg/L. Pond alkalinity can be increased to 20 mg/L through the addition of agricultural lime. For more information about liming ponds, ask your county Extension office for Circular ANR-232, "Liming Fish Ponds."

Maintaining good water quality is essential for good fish production. For a more complete understanding of water quality, ask your county Extension agent or Extension Fisheries Specialist for Circular ANR-195, "Channel Catfish Production In Ponds," and Circular ANR-826, "Management Of Recreational Catfish Ponds In Alabama."

Activity Around Cages. Fish confined in cages tend to be shy and easily disturbed. Frightened fish swim reactively, often colliding with the sides of the cage, which is extremely stressful. These collisions can cause bruising, skin abrasions, and fin damage, which can lead to slow growth, disease, and mortalities. **Cages should be placed in the pond where they will not be disturbed,** away from activities, such as fishing, boating, swimming, and livestock disruption. Keep activity to a minimum around the cages and approach cages only for feeding or other management activity.

Poaching or vandalism is a common problem in caged fish production. Ponds used in cage production should be in a place that can be watched, that has controlled access, and that is not easily seen from public roads. Access to cages can also be limited by maintaining locked gates on cage piers or securing boats that are used to access anchored cages.

Feeding Caged Fish

Caged fish must be fed nutritionally complete diets. Complete diets have adequate protein, balanced amino acids and energy levels, and supplements of all essential vitamins and minerals. Commercial feed companies manufacture both complete and supplemental diets. Cage producers must purchase complete diets, observe manufacturing dates, store appropriately, and feed properly if they are to be successful at producing fish.

Floating diets of 32 to 36 percent protein are adequate for producing catfish and tilapia in cages. Trout and hybrid striped bass need 40 to 42 percent protein diets. The feed pellet sizes that are available include $\frac{1}{8}$ -, $\frac{3}{16}$ -, and $\frac{1}{4}$ -inch diameter. Small fingerlings are best started on small pellets and then changed to larger pellets as they grow. The nutrient quality of diets deteriorates with age. **Caged fish should never be fed commercially packaged diets that are older than 60 days past the manufacturing date.** Heat and moisture also deteriorate feed quality and can encourage contamination by microorganisms (molds and bacteria). Contaminated feed can cause nutritional stress and disease. **Store feed in a cool, dry place and never feed wet, moldy, or discolored feed.**

All species of fish have an optimum temperature range for growth. Catfish and hybrid striped bass will grow best at temperatures between 75° and 85°F. Tilapia grow best at temperatures from 75° to 90°F. Trout growth is best between 55° and 65°F. Below these temperatures feeding activity is reduced and growth is slowed. At slightly above these temperatures, feeding activity is good but growth is reduced, while temperatures much above these can be lethal.

The amount of feed fish consume depends on their size, water temperature, dissolved oxygen concentrations, and other water quality factors like ammonia and carbon dioxide. Feeding rates are calculated on a percent-of-body-weight-per-day basis,

based on fish weight and approximate water temperature, with other water quality factors considered near optimum. Table 2 gives estimated consumption rates for catfish based on fish size.

Feeding the proper amount of feed is very important. Overfeeding is costly, wastes feed, and deteriorates water quality, which can lead to stress and disease. Underfeeding slows growth, reducing production and profitability. A few general rules

applied to feeding caged fish include the following:

- Observe feeding behavior carefully.
- Feed about the same time each day.
- Feed what the fish will consume within 20 to 30 minutes.
- Do not feed if D.O. is low or if ammonia or nitrite is high.
- Do not feed more than 35 pounds per acre per day without aeration or 60 pounds per acre per day with aeration.

- Keep accurate records on the amount of feed used and fish numbers.

Feeding activity is a producer's best indication of overall fish health and growth. Actively feeding fish are a good sign that everything is going well, at least for the moment. **Hand feeding is recommended for novice cage producers.**

Experienced cage producers can be successful using demand feeders. Automatic feeders are not recommended for cage production. Feeding rates are never constant day-to-day. One day fish may feed heavily and then reduce their feeding level by 30 percent the next day. It is a good practice to offer the fish only half of what they ate the previous day (based on feeding records), then, if that is consumed, offer them more.

Feeding in two or more increments, at 20-minute intervals, is probably the best way to evaluate feeding behavior without over-feeding. Reduced feeding for a day or two because of changing weather conditions or some other disturbance is common. Whenever fish feeding slows, producers should determine the cause. If feeding continues to decline or stops, something is definitely wrong. A cage producer must learn to watch feeding behavior and identify potential problems early.

Fish feed best when water temperatures and dissolved oxygen concentrations are high. Dissolved oxygen concentrations and water temperatures are generally good from mid-morning through dusk. Since D.O. starts to decline near dusk, recommendations have been to feed from mid-morning through late afternoon about the same time each day. Research done at Auburn in the 1990s, however, has shown that feeding catfish at or near dusk increases feeding response and growth. This research has shown daily growth rates can double by feeding near dusk and feeding until fish are satiated. Feeding in small increments for up to 1 or 1½ hours is the only way to feed fish to satiation without over-feeding. Table 3 gives average week-

Table 2. Estimated Daily Feed Consumption Rates For Various Sizes Of Catfish When Water Temperature Is Above 75°F (Applicable To Most Warmwater Fishes).

Average Weight (pounds)	Length Per Fish (inches)	% Body Weight Consumed
0.02	4	5.00
0.04	5	4.00
0.06	6	3.00
0.25	9.5	2.75
0.50	12	2.50
0.75	13.5	2.25
1.00	15	2.00
1.50	17	1.75

Table 3. Average Weekly Dusk Feeding Rates For Catfish Produced In Cages During The 1994 Summer Growing Season At Auburn University.¹

Date	Size of Fish (pounds)	Number of days fed ²	Total Feed/week (pounds)	Avg. feed/day (pounds)
4/28-4/30	0.1	3	2.2	0.73
5/1-5/7		7	5.5	0.79
5/8-5/14		7	18.1	2.6
5/15-5/21		7	16.7	2.4
5/22-5/28	0.16	7	19.2	2.7
5/29-6/4		7	27.3	3.9
6/5-6/11		7	29.3	4.2
6/12-6/18		4	21.2	5.3
6/19-6/25	0.28	7	37.3	5.3
6/26-7/2		7	40.8	5.8
7/3-7/9		6	41.5	6.9
7/10-7/16		7	64.6	9.2
7/17-7/23	0.68	7	82.9	11.8
7/24-7/30		7	91.3	13.0
7/31-8/6		5	90.8	18.2
8/7-8/13		5	89.5	17.9
8/14-8/20	1.18	6	88.2	14.7
8/21-8/27		5	90.8	18.2
8/28-9/3		5	94.8	19.0
9/4-9/10		7	94.2	13.5
9/11-9/17	1.55	5	80.9	16.2
9/18-9/24		5	67.9	13.6
9/25-9/26		2	24.0	12.0

¹Cages were stocked with 500 catfish and 20 tilapia per cage or 5.9 fish per cubic foot. Tilapia averaged 1.33 pounds at harvest. Fish were fed at dusk and fed to satisfaction over a period of 1½ hours. Nightly aeration was provided continuously from 11:00 PM through 7:00 AM using air-lift pumps. Feed conversion averaged 1.8 pounds of feed per pound of fish growth throughout the study.

²Fish were not fed during severe weather, therefore days per week may not equal 7.



Hand-feeding active, healthy fish.

ly dusk feeding rates during a research trial of a single growing season. These feeding rates should only be used as an example of what fish will eat when pond conditions are good. Note that feeding increases sharply in July as water temperatures finally warmed after an unusually cool June. **Dusk feeding should not be considered unless aeration is available.** Emergency aeration is not sufficient. Aeration must be provided routinely to maintain adequate D.O. concentrations throughout the hot summer nights if dusk feeding is to be successful.

Finally, it is very important not to overfeed. Ponds are excellent recyclers of nutrients, but all systems have a limit to what they can absorb or assimilate. Given time, the pond's ecological systems will decompose, store, and release the nutrients it receives. Overfeeding can push pond systems past the point at which caged fish can survive and prosper. Ponds without aeration can usually assimilate 35 pounds of feed per surface acre per day during the summer and have few oxygen depletions. Ponds with aeration can generally assimilate up to 60 pounds of feed per surface acre per day during the sum-

mer and have few oxygen depletions. Ponds with aeration can generally assimilate up to 60 pounds of feed per surface acre per day. Run-off from fertilized fields or livestock pastures can reduce the amount of feed a pond can effectively assimilate. Cage producers should start out stocking and feeding conservatively until the limits of their pond and management needs are identified and understood.

Harvesting And Marketing

One of the primary benefits of cage culture is the ease of harvest. Fish can be harvested from a cage by simply dipping them out with a dip net. The cage can be brought to the shore for easier access to a complete harvest. Harvesting can begin whenever the fish reach market size. Suitable harvest sizes generally range between $\frac{3}{4}$ pound and 2 pounds, depending on the chosen market. In the case of warm water fish such as catfish, the harvest generally begins in September or October, depending on the size and time fingerlings were stocked.

Some fish may reach market size before the rest and may be removed by grading or partial harvest. Partial harvests may be stressful to the remaining fish, particularly if the temperatures are above 65°F. It should also be cautioned that reducing the stocking density by partial harvest before the water temperature drops to around 65°F may induce stress and increase fighting among the remaining fish. Fighting may also occur if the fish get too large. Fighting among the fish can lead to stress, injuries, and potential diseases. Cage produc-



Harvesting of caged fish.

ers report that cages with fish densities of less than 2.5 fish per cubic foot have increased incidences of fighting.

Prior to harvesting fish for sale, it is critical to sample the fish for off-flavor. Cage-raised fish are susceptible to off-flavor, just as are fish that are raised in open ponds. It appears, however, that off-flavor incidence in cage-raised fish is less common. Off-flavor occurs most often in the warmer months but it can occur at any time of the year. If the fish have any strange odors or flavors (musty, muddy, oily, etc.), harvest should be postponed. The fish should be checked weekly and harvested when they are on-flavor. Most off-flavors will diminish in a few weeks if the water quality is good. For more information on testing for off-flavor, ask for SRAC publication No. 431, "Testing Flavor Quality Of Preharvest Channel Catfish." **If you want repeat customers, never sell any fish that you suspect is off-flavor.**

Withholding feed for several days prior to harvest will purge the fish of wastes in its digestive system. These "cleaned-out" fish will be easier to transport and process. **Keep records!** Record the weight of fish harvested for production and economic evaluation.

Marketing

Innovative and effective approaches to marketing are usually the key to financial success or failure to small aquaculture producers. **Regardless of the size or type of venture, a marketing plan or strategy is an essential component of success.** There are a number of ways to sell fish, but the most profitable way is usually directly to the consumer. Fish can be sold to any number of markets either live from the cage or with some processing. Potential marketing outlets should be examined before



Live fish markets produce the highest profits for the caged fish farmer.

production or harvesting takes place. If you plan to do your own processing, make sure that you comply with current health and safety regulations. Contact your county health department or Extension Fisheries Specialist for further information on processing regulations. Certified custom processing services are available in a number of places in Alabama. Using one of these services is often the most cost effective, legal way to sell dressed fish.

Which markets you choose depend on several factors, including the following:

- The amount of time and money you have to spend marketing.
- The number of fish you have to sell.
- Your ability to process and transport the fish.
- Your proximity to the markets.

Direct retail sales, where the producer sells directly to the consumer, is generally where the greatest per unit profit is realized. Direct retail sales to consumers are a good place to start if you have small quantities or if availability of the product is uncertain. Methods of direct retail sales include the following:

- Local customers.
- Roadside markets.
- Value added markets (selling custom processed fish).
- Cage harvesting sale at the pond bank.
- Fish fry or fund-raiser.
- Office building sales.
- Fairs and festivals.

Other wholesale markets include the following:

- Fee-fishing lakes.
- Live-haulers.
- Local restaurants.
- Local supermarkets.
- Specialty and ethnic stores.

The decision of how to market is up to you, but remember, sales directly to consumers will be the most profitable. In general, the simpler the plan and the fewer the middlemen, the better. Setting up your own “processing outlet” is often the least profitable and most risky marketing option. For more information on small-scale marketing and description of the markets listed above, see Circular ANR-962, “Marketing Options For Small Aquaculture Producers.”

Common Problems

Diseases are a problem in all types of aquaculture. Bacterial diseases like ESC (enteric septicemia of catfish), Columnaris, and Aeromonas, are particularly common in cage fish. Parasites also can cause disease episodes. The high density of fish in cages enables diseases to spread rapidly. Figure 3 shows that most cage disease problems occur in late spring. This period coincides with water temperatures of 70° to 80°F. Disease organisms appear to be most active at these temperatures, and although fish are starting to feed well,

their immune systems do not seem to function adequately at these temperatures. Signs or symptoms of stress and disease include the following:

- Discolorations on skin or fins.
- Erratic swimming behavior.
- Swimming near the surface and swimming lethargically.
- Gulping or piping at the surface.
- Reduced or suspended feeding activity.
- Dead or dying fish.

If these signs appear, the producer should take immediate steps to find out why.

Is the D.O. low?

Were the fish recently stressed by hauling, handling, low D.O., or high ammonia or nitrite?

Has the weather changed suddenly?

Have feeding rates been declining or has feeding suddenly stopped?

How old is the feed being used?

Is the feed discolored?

If a disease is suspected, catch one or more **live** fish with symptoms and ship them or take them personally to a fish diagnostic lab. For more information on collecting and shipping diseased fish, ask your county Extension office for Circular ANR-562, “Guidelines For Collecting And Shipping Diseased Fish.”

Pond Problems. Nearly all of the non-disease-related fish losses are the

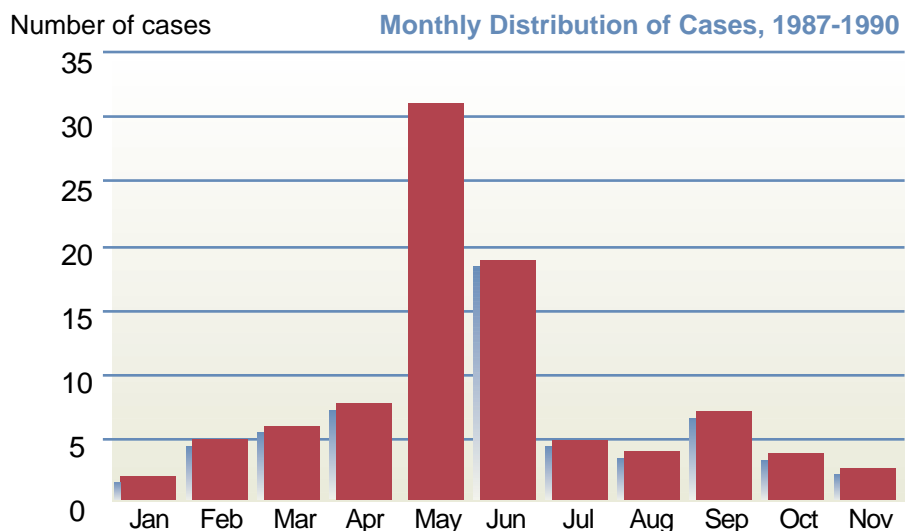

Figure 3. Caged fish diseases highest in late spring.

result of poor water quality. A lack of oxygen or critically low dissolved oxygen concentrations, accompanied by other adverse conditions such as high carbon dioxide and low pH, is the primary reason for losses. Several environmental occurrences can cause these conditions. The following are potential causes of these conditions.

Cloudy Weather. Sunshine and phytoplankton, through photosynthesis, are responsible for almost all of the oxygen dissolved in ponds. Therefore, even one or two days of cloudy or overcast skies—and certainly several consecutive days with little or no sunshine—will restrict photosynthesis and oxygen production, potentially resulting in low D.O. conditions. This is particularly true in ponds with heavy phytoplankton blooms.

Pond Turnover. The term “turnover” refers to the mixing of stratified pond waters. In most ponds deeper than 4 to 5 feet there will be some thermal stratification (layering of warm and cold waters). In fish ponds the sunlight penetration will be limited to the upper few feet of the pond. As a result, this upper layer will be warmer, the phytoplankton will stay in this layer, and most of the oxygen will be produced and remain in the top few feet. The deeper, cooler layer of the pond (often a much larger volume than the warm top layer) contains little or no oxygen because dead organic material sinks, decomposes, and uses up oxygen. During a strong wind or hard, cold rain the top layer could be cooled enough so that the two layers mix. This results in the large volume of oxygen-depleted water mixing with the small volume of oxygen-rich water, creating a net oxygen deficiency throughout the pond. In severe cases this event can cause fish kills. Supplemental aeration around the cage can help prevent losses if a turnover occurs (see Cage Placement And Water Quality section).

Plankton Die-off. Pond phytoplankton populations will sometimes

die all at once. The causes of these plankton die-offs are not fully understood, but severe low D.O. conditions almost always follow. An indication that a die-off is occurring is a rapid (within hours) change in water color, usually a darkening followed by a clearing of the water. Visibility increases followed by changing of water color from green to a dilute coffee brown often streaked with black or white. This condition is often accompanied by a distinct odor often described as a “hog pen” smell. By this time D.O. concentrations are usually critically low. Corrective measures are generally limited to emergency aeration until the condition corrects itself, usually within 2 or 3 days.

Biofouling. Biofouling is the attachment of algae or bryozoans (soft, jelly-like animals) to the cage. This biofouling reduces the effective mesh size and restricts water movement through the cage. Two species of bryozoans have been responsible for the majority of cage fouling problems. The worst of the two is a clear, jelly-like mass (usually ball shaped) that attaches to the cage and grows very rapidly. The other grows along the mesh of the cage like a flat, dark reddish or gray “sponge.” Contact an



Bryozoans in cage.

Extension Fisheries Specialist for recommendations on your biofouling problems.

Physical losses to predators (animal and human) and escapement into the pond account for the remainder of fish losses. The greatest potential for losses comes from poachers who may steal a few or an entire cage of fish. Minor fish losses

have been attributed to snakes and herons. However, a heron routinely sitting on the cage can cause severe stress for the fish in the cage, particularly in clear water. Raccoons will take dead and dying fish and will eat feed left floating in the cage. Major losses have occurred through holes made in net cages by turtles trying to get dead fish. Muskrats, otters, minks, and rodents have been known to cut through net cages.

Overwintering Fish. Catfish and hybrid striped bass may need to be overwintered in cages either to provide fish for continuous markets or to get fish to market size. A common problem in cage culture is “shorts” or fish that do not reach market size during the growing season and must be overwintered so that they can grow to market size during the next season. Overwintering of fish in cages can be a problem. The fish probably have been stressed during the harvesting of the market-size fish from that cage. Water temperatures are starting to fall, which means that the fish will reduce feeding and their immune system function will be impaired.

If water temperatures fall rapidly, fish usually will stop feeding for several weeks until temperatures stabilize. The mistake that many cage producers make is thinking that the fish will not feed during the winter because they have stopped for a few weeks during rapid temperature declines.

Research has shown that fish will grow up to 20 percent through the winter (Figure 4), if fed a complete commercial floating diet of 28 to 32 percent protein on a winter feeding schedule (see Circular ANR-457, “Feeding Of Catfish During Winter”). Caged fish should be fed in the late afternoon on the warmest days, fol-

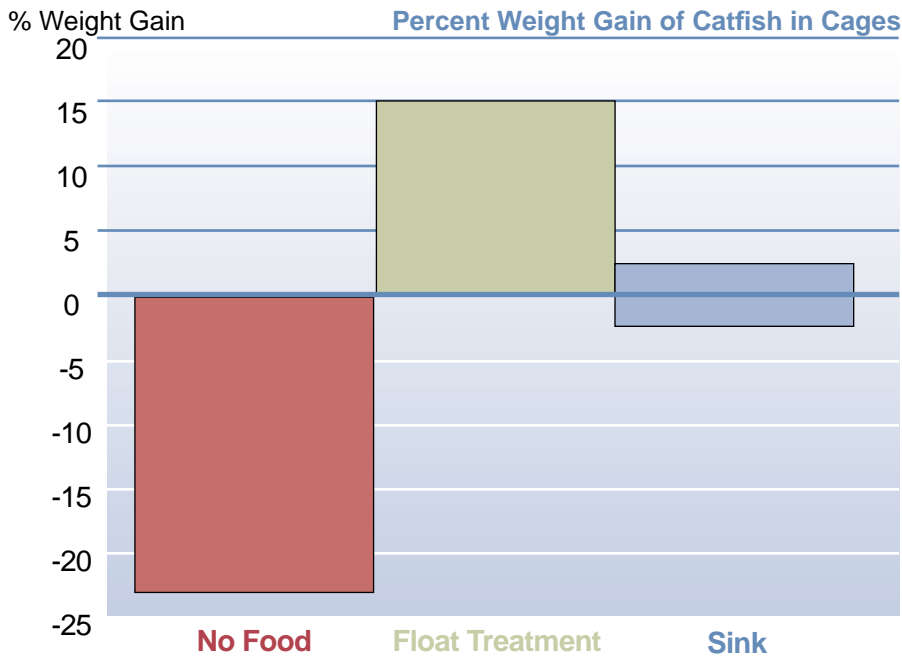

Overwintered caged catfish grew well on floating feed as opposed to no feed or sinking feed.

lowing the winter feeding schedule. Sinking feed can be fed by placing it on a tray located on the cage bottom. The tray for sinking feed must have sides (at least 2 inches high) to keep fish from sweeping the feed off the tray and out of the cage.

Cage culture is intensive aquaculture. Aquaculture like any agricultural activity has risks and is not a get-rich-quick scheme. The possibility for problems and failures are significant until producers have gained experience. Experience must be gained in both production and marketing skills. Cage culture has the potential to be profitable and rewarding but should be approached with caution. Evaluate your site and potential markets carefully, talk with other producers, start small, avoid stressing the fish, stay alert, ask for assistance when problems occur, and develop your markets.



ANR-957

Michael Masser, *Extension Fisheries Specialist*, Associate Professor, Fisheries

David Cline, *Extension Aquaculturist*, Fisheries

For more information, call your county Extension office. Look in your telephone directory under your county's name to find the number.

Issued in furtherance of Cooperative Extension work in agriculture and home economics, Acts of May 8 and June 30, 1914, and other related acts, in cooperation with the U.S. Department of Agriculture. The Alabama Cooperative Extension System, (Auburn University and Alabama A&M University), offers educational programs, materials, and equal opportunity employment to all people without regard to race, color, national origin, religion, sex, age, veteran status, or disability.
UPS, 6.5M49, New 1:96, ANR-957