

LIPID METABOLISM AND VITAMINS AND MINERAL

INTRODUCTION

1. General

A. Lipids:

- 1) Include a group of substances that are insoluble in water, but soluble in ether, chloroform & benzene.
 - 2) Include fats, waxes, glycolipids, phospholipids, steroids, prostaglandins, etc.
 - 3) "Fats" are by far the most important lipids based on amounts present in the animal body & its food.
 - 4) But others also play significant roles in nutrition & physiology - e.g., cholesterol is a precursor of vitamin D and sex hormones, and it is an infamous component of atheromatous plaques of cardiovascular diseases!
- "Lipids" - Preferred terminology because this terms includes all the important substances, whereas "fat" has more strict definition/meaning!? For instance, fats = glycerol + 3 fatty acids or FA.

B. Lipids in diets for nonruminant species:

- 1) Baby pig's diet (milk) consists of 6-8% fat (30-40% on a DM basis). (Others - 80% water, 5-6% protein & 4.5-5% lactose.)
- 2) Lipid content in grains - Corn, \approx 3.6%; milo, \approx 2.8%; barley & wheat, less (< 2%).
- 3) Soybean & other oilseed meals (solvent extracted) are low in lipids (< 2-3%).
- 4) Animal protein sources (fish meal, meat meal, etc.) are relatively high (6-10%).
- 5) Corn-soy-based diets usually contain \approx 2.5-3% fat.

C. Some reasons for using feed grade lipids in nonruminant diets:

- 1) To improve growth rate & feed efficiency.
 - 2) To reduce dustiness of feed, and also in confinement buildings.
 - 3) To \uparrow energy content of sow's milk, \therefore increase the survival rate of baby pigs.
 - 4) To reduce segregation of smaller particles.
 - 5) To facilitate the pelleting process.
 - 6) To reduce wear & tear on mixing and handling equipment.
- ... , etc.

2. Classification of Lipids

A. Based on the No. of carbon atoms and the degree of unsaturation:

- 1) Saturated fatty acid (SFA) - No double bonds.

- 2) Unsaturated fatty acid (UFA) - One or more double bonds.
- 3) Polyunsaturated fatty acids - Two or more double bonds.

B. Natural lipids (plant & animal origin):

- 1) Made up of triglycerides (glycerol + 3 FA).
- 2) Most FA have 8 to 24 C with 16 to 18 C being common for many feed lipids.
- 3) Short (< 10 C) or medium chain FA - FA with 14 C or less.

3. Physical and Chemical Characteristics of Lipids (Maynard et al., 1979)

Item	Corn	Soy	Saf- flower	Coco- nut	Past. grass	Butter	Tallow	Lard	Egg
Saturated acids, %									
Butyric C14:0						3.2			
Caproic C6:0				0.2		1.8			
Caprylic C8:0				8.2		0.8			
Capric C10:0				7.4		1.4			
Lauric C12:0				47.5		3.8			
Myristic C14:0			0.2	18.0	1.0	8.3	3.0		0.3
Palmitic C16:0	7.0	8.5	12.3	8.0	16.0	27.0	27.0	32.2	22.1
Stearic C18:0	2.4	3.5	1.8	2.8	2.0	12.5	21.0	7.8	7.7
Total	9.4	12.0	14.3	92.8	21.1	58.8	51.0	40.0	30.1
Unsaturated acids, %									
Palmitoleic C16:1					2.0				3.3
Oleic C18:1	45.6	17.0	11.2	5.6	3.0	35.0	40.0	48.0	36.6
Linoleic C18:2	45.0	54.4	74.3	1.6	13.0	3.0	2.0	11.0	11.1
Linolenic C18:3		7.1			61.0	0.8	0.5	0.6	0.3
Arachidonic C20:4									0.8
Total	90.6	78.5	85.5	7.2	79.0	38.8	42.5	59.6	52.1
Melting point, °C	< 20	< 20	< 20	20-35		28-36	36-45	35-45	
Iodine No.	105-125	130-137		8-10		26-38	46-66	40-70	
Saponification No.	87-93	190-194		250-260		220-241	193-200	193-220	

- A. Most commonly used lipids/lipid sources? – Those containing 16 to 18 C.
- B. In general, plant sources are highly unsaturated, whereas most animal sources are 50:50. The ratio of saturated to unsaturated or vice versa has some implications on the efficiency of lipid utilization!

ESSENTIAL FATTY ACIDS

1. Dietary Requirements

A. "Essentiality" of fatty acids:

- 1) Earlier?

- a) Recognized the need for certain lipids by the animal.
 - b) But, also recognized that carbohydrates can be converted into lipids readily.
 - c) Thus, assumed for a long time that there is no need for dietary lipids.
- 2) Evans & Burr (1926. Proc. Soc. Exp. Biol. Med. 24:740) indicated that "*a component of fat other than fat-soluble vitamins are dietary essential for rats!*"
 - 3) Burr & Burr (1929. J. Biol. Chem. 82:345):
 - a) Feeding the diet almost devoid of fat to rats resulted in a poor growth, symptoms of dermatitis, necrosis of tails and death.
 - b) Also observed adverse effects on reproduction & lactation.
 - c) Small amounts of polyunsaturated fatty acids or PUFA were effective in preventing/curing those conditions, but saturated fatty acids were ineffective.
- Later, arachidonic and linolenic acids were found to be partially effective, and these two and linoleic acid were referred to as "essential fatty acids!"

B. Swine & chicks:

- 1) Demonstration of the essentiality of FA:
 - a) For chicks by Reiser in 1950 (J. Nutr. 42:319).
 - b) For swine by Whitz and Beeson in 1951 (J. Anim. Sci. 10:112).
- 2) Deficiency symptoms:
 - a) Swine - e.g., poor growth, skin lesions, retarded sexual maturity, underdeveloped GI systems, etc.
 - b) Birds - e.g., ↓ growth & disease resistance, dermal problems, faulty feathering, fatty livers, ↓ development of secondary sex characteristics, etc.

2. Essential Fatty Acid Activity

A. Essential FA "activity," NOT "essential FA?" - Possible reasons?

- 1) Interconversion among FA, i.e., FA provided in the diet may not be the one that is responsible for alleviating the deficiency symptom(s)!
- 2) Fatty acids are involved in a wide range of metabolic processes in animals:
 - a) May exhibit many manifestations of dietary essential FA deficiencies.
 - b) May respond differently to various FA depending on deficiency symptoms.

B. Fatty acids to be active:

- 1) Important to have unsaturated bonds between carbons 6-7 and 9-10 from the methyl end of FA chain [. . . known as omega (ω) carbon], which give FA the correct configuration!
- 2) Activity of various FA:

- a) Linoleic acid (US bonds at 6-7 & 9-10 positions) - Has a 100% activity, and animals can synthesize arachidonic acid from linoleic acid.
- b) Arachidonic acid (US bonds at 6-7, 9-10, 12-13 & 15-16 positions) has a 100% activity.
- c) Oleic acid (an US bond at 9-10 position) has no activity because animals cannot unsaturate the 6-7 bond.
- d) Linolenic acid (US bonds at 3-4, 6-7 & 9-10 positions) - Not effective because the “3-4” bond destroys a critical configuration, and although animals can saturate this bond, \therefore has a limited activity.

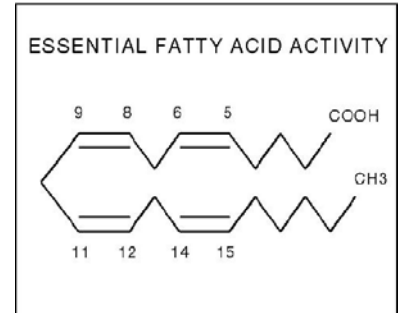

3) Essential FA:

- a) From a metabolic standpoint, “arachidonic acid” is the essential FA.
- b) From a dietary standpoint, “linoleic acid” is the essential FA because of:
 - (1) Conversion of linoleic to arachidonic acid.
 - (2) Low arachidonic acid contents in feeds.

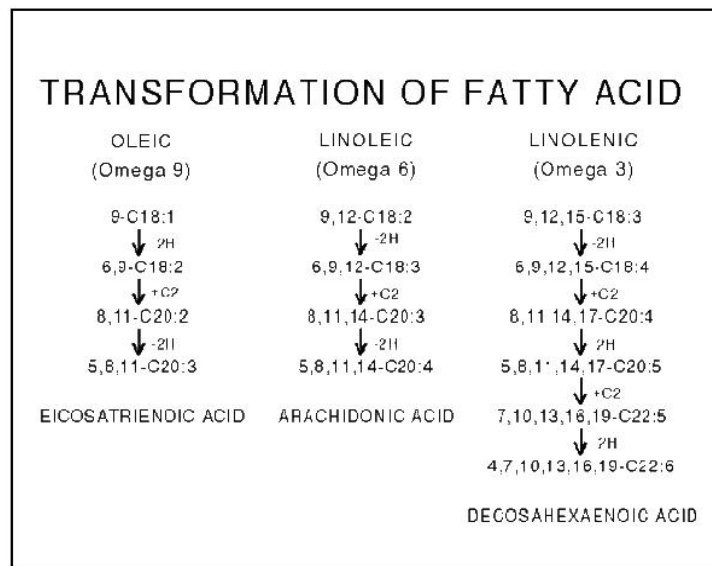

C. Metabolic transformation of FA:

- 1) Conversion by microsomal chain elongation or desaturase system.
- 2) Competition among series because of the use of the same enzyme systems:
 - a) ω -3- & ω -6-family can suppress metabolism of each other.
 - b) ω -6 family can suppress formation of PUFA from oleic acid.
 - Affinity for enzymes? Linolenic (ω -3) > linoleic (ω -6) > oleic (ω -9)!

D. The cat family (e.g., cats & lions):

- 1) Unable to desaturate linoleic & linolenic acids (NRC, 1986).
- 2) Thus, they require specific polyunsaturated FA of animal origin such as eicosapentaenoic acid or EPA and docosahexaenoic acid or DHA.

3. Functions of Essential Fatty Acids

- A. Important components of cellular membranes and subcellular structures (e.g., mitochondria) - Present as phospholipids & provide “fluidity” to the membrane, which is essential for cellular functions.
- B. Involved in the synthesis of arachidonic acid derivatives, which are synthesized and incorporated into the phospholipids of cell membranes - e.g.:
 - 1) Prostaglandins - Involved in vasoconstriction/vasodilation, ♀ reproductive cycles, lipid metabolism, etc.
 - 2) Prostacyclin - Involved in vasodilation, inhibition of platelet aggregation, etc.
 - 3) Thromboxanes - Involved in vasoconstriction, stimulation of platelet aggregation (clotting), etc.
 - 4) Leukotrienes - Mediators of allergic response & inflammation, also potent vasoconstrictors, etc.

4. A Source of Linoleic Acid?

- A. Linoleic acid - Sources: [Stahly, 1984. In: Wiseman (Ed.); NRC, 1988]

Source	Percent	(NRC, 1988)
Safflower oil	78	
Sunflower oil	68	
Corn oil	55	(58.0%)
Soybean oil	50	(65.7%)
Cottonseed oil	50	
Peanut oil	27	
Poultry fat	25	(11.8%)
Lard	10	(18.3%)
Fish oil	2.7	
Beef tallow	1.5	(3.1%)
Milk fat	1.5	
Coconut oil	1.5	
Corn	1.8	
Oats	1.5	
Wheat	.6	
Barley	.2	
Soybean meal	.3	

- B. Animal fats tend to be low in linoleic acid.
- C. Plant oils tend to be high in linoleic acid, especially in forage lipids - e.g., pasture grasses contain \approx 60% of lipids as linolenic acid.

D. The content and(or) type of animal fats can be influenced by the concentration and type of dietary lipids!

1) Effect of various “oils” on carcass fatty acids in pigs: (Maynard et al., 1979)

Item	Firmness	Melting point, °C	Iodine No.	Oleic	Linoleic	Total SFA
Peanut, 4.1%	Medium	34.3	72	47.9	13.8	32.5
Cottonseed, 4.1%	Hard	45.3	64	35.9	15.7	43.0
Soybean, 4.1%	Medium	31.2	76	43.3	18.6	33.8
Corn, 4.1%	Medium	36.3	76	45.0	16.8	33.0
Corn, 11.5%	Oily	24.5	97	41.4	31.4	23.1

* Total SFA = total saturated fatty acids; Lard = ~ 40% saturated FA & ~ 11% linoleic acid.

2) “Soft” pork:

- a) Oily & difficult to handle.
- b) Fats are unstable, ∴ susceptible to rancidity. (Not a major problem today because of refrigeration! But, still . . .?!)

- **The bottom line?** If consumers demand meat products with “less saturated fat or more linoleic acid,” can be done by dietary manipulations!

5. Fatty Acid Requirements

A. Birds (linoleic acid): (NRC, 1994)

- 1) Poultry (chickens, hens & broilers) - 0.83 (hens with 120 g of feed/day) to 1.25% (hens with 80 g of feed/day), with 1.00% for all others.
- 2) Turkeys - 0.8% (8-24 wk & breeders/holding), 1.0% (up to 8 wk), and 1.1% for laying hens.

B. Swine (linoleic acid):

- 1) ARC, 1981 - 3 & 1.5% of dietary DE for pigs up to 30 kg & from 30-90 kg, respectively.
- 2) NRC, 1998 - 0.10% for all classes of pigs.
 - These levels are usually present in typical cereal-protein supplement-based diets (e.g., corn, 1.8% & soy, 0.30%).

C. Fish: (NRC, 1993)

- 1) Fresh water fish generally require either dietary linoleic acid or linolenic acid, or both - 0.5 to 2.5% depending on estimates/species.

- 2) Marine fish require dietary eicosapentaenoic acid [EPA; 20:5 (n-3)] and(or) docosahexaenoic acid [DHA; 22:6(n-3)] - 0.5 to 2% of EPA & DHA depending on estimates/species.

D. Factors that influence the “essential FA deficiency,” ∴ the requirement:

- 1) Age & carryover effects (e.g., from the egg to chick).
- 2) Growth rate.
- 3) Sex - ♂ may need more (e.g. in rats, 10-20 mg for ♀ vs > 50 mg/d for ♂).
- 4) Humidity & water balance - Related to dermal conditions.

FATTY ACIDS AND HUMAN HEALTH

1. ω-3 Family (Linolenic) PUFA

A. Health benefits (based on epidemiological studies)?

- 1) A low death rate from a coronary heart disease (CHD) among Greenland Eskimos (subsist entirely on a marine diet high in ω-3 FA).
 - 2) Lower death rate from CHD in Japan (higher fish consumption).
- The “relationship?” - Originally hypothesized to be via antithrombotic effects, i.e., ↓ platelet adhesion & aggregation!

B. The evidence? (e.g., Wallingford et al., 1991. Nutr. Rev. 49:323)

- 1) “Fish or fish oil?” (Most of fish in the Eskimo studies were not high in ω-3 FA!)
 - a) Positive or no response in some studies on fish/fish oil, and marginal effect in other studies.
 - b) Cannot distinguish between effects of fish consumption or fish oil consumption *per se* in studies with a positive response.
- 2) Primary endpoints should be myocardial infarction & death from CHD! - Only one 2-yr prevention study to date, in which reported the ↓ death from CHD but no ↓ in non-fatal myocardial infarction. (Made no comparison of the effects of fish or fish oil consumption in that study, thus . . . ?)
- 3) Blood lipids:
 - a) A widespread agreement that fish oil ↓ TG & VLDL in subjects with high initial values.
 - b) The importance of TG level in CHD-risk is still a matter of debate!
 - c) In many studies, observed no effect of fish oil on a total serum cholesterol, LDL or HDL level. (One study with a positive response (i.e., ↓ total cholesterol by feeding 30-40% calories from fish oil) was confounded with PUFA.)

4) Blood pressure:

- a) Observed ↓ BP with ω -3 FA in hypertensive persons.
- b) Observed ↓ BP with fish oil in a large study with normal healthy subjects, but also observed comparable ↓ with “olive oil” placebo, thus the effect was not specific to fish oil?

5) Thrombosis:

- a) Spontaneous platelet aggregation has been reported to be inversely related to an occurrence of myocardial infarction & CHD death in survivors of heart attacks.
- b) Observed ↓ platelet adhesion & aggregation & ↑ bleeding time with fish oil consumption. (This might be an important line of evidence that would support health claim/message for ω -3 FA.)
- c) Prolonged bleeding time: (McDowell, 1989)
 - (1) May ↓ a platelet plug formation in damaged blood vessels.
 - (2) May inhibit vessel wall-induced clotting of plasma.

6) Vessel wall effects:

- a) Observed ↓ production of superoxide, interleukin-1 & tumor necrosis factor from leukocytes among "fish oil-supplemented normal subjects."
- b) Also, observed ↓ production of platelet dependent growth factor & endothelium-derived relaxation factor in rats supplemented with fish oil.
 - All these effects may ↓ the progression of early stages of atherosclerosis!

2. Linoleic Acid (ω -6)

A. Suggested beneficial effects of linoleic acid? (Vergoesen, 1977. Nutr. Rev. 35:1)

- 1) ↓ blood cholesterol & TG levels,
- 2) ↓ thrombotic tendency of platelet,
- 3) Preventive & curative effects in a Na-induced hypertension, etc.

B. ↑ linoleic acid intake: (McDowell, 1989)

- 1) Mechanisms of these responses/beneficial effects summarized by Vergoesen (1977) are unknown, or not clearly established.
- 2) Prostaglandins:
 - a) Pharmacological data - Atherosclerosis-promoting factors (hypertension, ↑ thrombotic tendency of platelet) can be counteracted by arterial dilation, and ↑ water & Na diuresis induced by certain prostaglandins.

- b) Preventive & curative effects of linoleic acid on atherosclerotic syndrome may be explained by ↑ prostaglandin synthesis.

DIGESTION AND ABSORPTION

1. Pre-Duodenal Digestion

- A. Intragastric lipolysis has been demonstrated in rats and humans.
- B. Has not been described or demonstrated in the pig or chick, but probably exists.
- C. It is likely that both oral and gastric lipases operate in the stomach, i.e., the initial modification of dietary lipids.

1) Lingual lipase:

- a) Activation at pH 2.7-7.5 with optimum, 3.0 - 6.0.
- b) Mostly work on ester links at 3-TG, resulting in FA with & 1,2-diacylglycerol

2) Gastric lipase:

- a) From stomach glands - Chief & parietal cells?
- b) Same as lingual lipase?

3) In the past, questioned the contribution of the stomach to overall lipid digestion, and assumed that most lipids are delivered to the duodenum "unchanged" in nonruminant species), but according to Yen (2001):

- a) Fat globules may be broken into droplets because of body temperature, intense mixing, agitating, and sieving action of the distal stomach.
- b) Gastric lipase of newborn & 16-d-old milk-fed pigs was found to hydrolyze 25 to 50% of dietary lipids to diglycerides, monoglycerides, and free fatty acids (Netport and Howarth, 1985; Chiang et al., 1989).

- Contribution(s) to the overall digestion - ???

2. Digestion & Absorption of Triglyceride

- A. Triglyceride (TG) absorption - Redrawn from Maynard et al. (1979) [Should be: E = TG & T = monoglyceride!]

B. Brief Summary

- 1) A coarse emulsion enters the duodenum from the stomach or gizzard.
- 2) Bile salts interact with fat droplets to form emulsion droplets, and along with lipase & colipase, reduce lipids to finer emulsions.
- 3) Lipase and colipase:

- a) Hydrolyze TG droplets into FA and monoglycerides.
- b) Preferentially remove FA in 1 & 3 positions, leaving 2-monoglycerides.
- c) Colipase & bile salt both needed for the lipase activity?

- (1) Without colipase or bile, lipase is absorbed & denatured at the interface.
- (2) With bile salt but no colipase, lipase remains in the aqueous phase.

- d) Colipase is required for the attachment/function of lipase at the substrate-water interface.

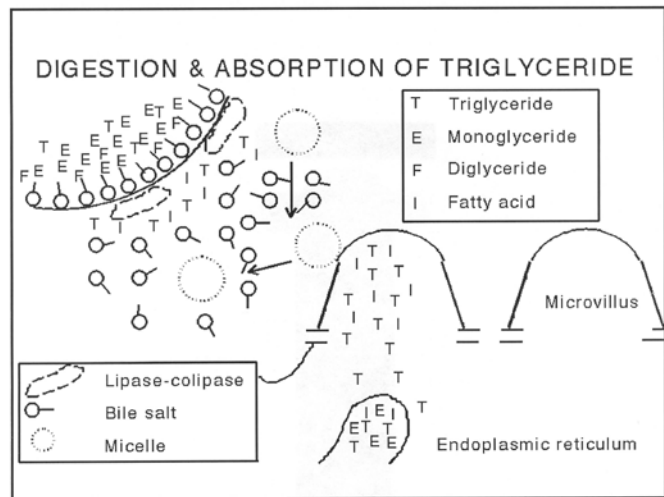

C. Formation of micelles:

- 1) Consist of 2-monoglycerides, FFA & bile salts.
- 2) Outside, polar (hydrophilic) & center, non-polar (lipophilic).
 - The rate of formation is a critical step in fat digestion/absorption!

D. Migration of micelles to the brush border (lower duodenum):

- 1) Micelles are disrupted.
- 2) FA & monoglycerides are absorbed.
- 3) Bile salts - Reused/eventually absorbed at the lower tract & recirculated via the liver.

E. Absorbed monoglycerides and FA are resynthesized into TG and phospholipids.

F. TG are combined with cholesterol & phospholipids to form chylomicron (pig) or very low density lipoprotein (fowl):

1) Apoprotein B:

- a) Synthesized by the rough ER, and being incorporated into lipoproteins in the smooth ER, which is the primary synthetic site of TG.
- b) Essential for the formation of chylomicron and VLDL.

2) Swine - Absorbed into the general circulation via the lymphatic system . . . The jejunum is a major site.

3) Chicks:

- a) Via the portal system (the lymphatic system is poorly developed).
 - b) Also, absorbed at the duodenum & ileum.
- G. Glycerol is passively absorbed.
- H. Short-chained FA (< 10 C), which are relatively soluble in water, are absorbed without micelle formation via the portal system.
- I. Large intestine: (Yen, 2001)
- 1) Some synthesis or secretion of lipid within the LI of the pigs because more total lipid is excreted into the feces than is passed through the terminal ileum.
 - 2) During the passage through the LI, unsaturated FA are hydrogenated, and cholesterol (e.g., reduced to metabolites), bile acids (e.g., release free bile acids), and others are altered by the microflora.
 - 3) Microbial degradation of triglycerides yields free long-chain FA (. . . hydrogenated before forming Ca soaps?) and VFA.
 - Importance/significance - ???

3. Factors Affecting Digestion & Absorption

- The efficiency seems to be associated with the ability to form micelle, which is affected by the degree of unsaturation, chain length, relative concentration of free vs. esterified FA, etc. . . . perhaps, influencing the solubility in bile salt solution!?

- A. Short & medium-chained FA (≤ 14 C) are utilized better vs long-chained FA.
- B. Unsaturated FA are utilized better than saturated FA.
- C. The degree of esterification:
 - 1) Removal of FA - > TG > DG > MG.
 - 2) Absorption - MG > FA.
- D. The ratio of unsaturated/saturated FA:

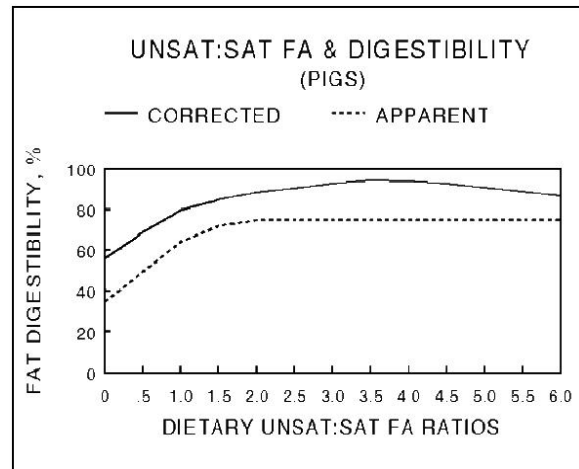

- 1) "UFA/SFA ratios" & digestibility - See the figure [Stahly, 1984. In: Wiseman (Ed.)].
- 2) Effect of dietary fatty acids on fat digestion in pigs: [Stahly, 1984. In: Wiseman (Ed.)]

Item	Supplemental fat	UFA:SFA	Digestibility, %
Corn-soy	Tallow	1.5	85-92
Barley-soy	Tallow	1.0	70-85
Corn-soy	Soy oil	4.8	90-95
Barley-soy	Soy oil	4.0	90-95

- The bottom line? - When using animal fats, a source of grain may be important, whereas it may not be that important when using plant oils.

METABOLISM

1. Post Absorption

- Enter oxidative pathways for energy production.
- Or, transported to adipose cells & incorporated into the body fats.
- Fatty acids - Transported in the blood as free FA:
 - Free fatty acids - Refer to unesterified fatty acid or nonesterified fatty acids (NEFA).
 - In plasma, longer-chain FA are combined with albumin, and they are attached to a fatty acid binding protein in the cell, thus not really "free!?"
 - Just like glucose, must be activated via one step process before being metabolized:

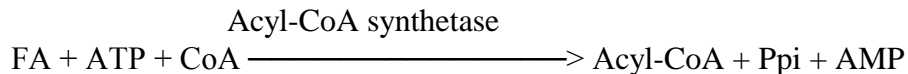

2. β -Oxidation

- β -Oxidation of palmitic acid - Redrawn from Maynard et al. (1979).
- Acyl CoA cannot pass into the inner mitochondria membrane alone, thus need a special carrier mechanism, "carnitine transport system (carnitine acyl transferase I & carnitine acyl transferase II).

- Activation of smaller FA and their oxidation within mitochondria may occur independent of carnitine, but not the long-chain NEFA or acyl-CoA.
- Carnitine:
 - Synthesized from Lys and Met in liver and kidney.
 - Distributed widely, and is particularly high in muscle.

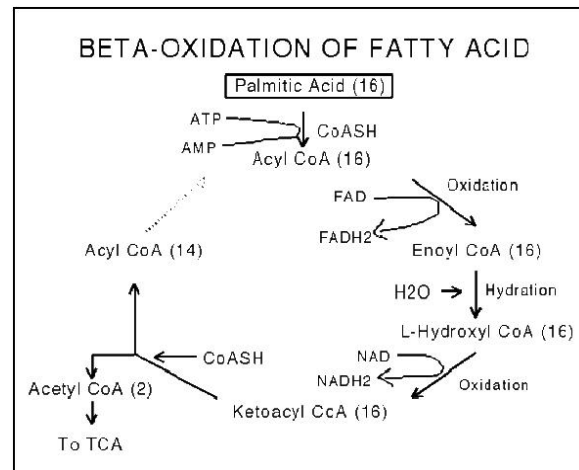

- Remove "2-C unit" at a time & 2-C units enter the citric acid cycle as acetyl CoA.
 - Two C are cleaved at a time from acyl-CoA starting at carboxyl end.
 - Chain is broken between $\alpha(2)$ - & $\beta(3)$ -carbon atoms, thus the name β -oxidation.
 - The 2-C units formed are acetyl CoA, thus, palmitoyl-CoA forms 8 acetyl-CoA molecules.
- Glycerol enters the glycolysis pathway through triose sugar.

- 1) 2 glycerol \rightarrow 2 glycerol-P (- 2 ATP).
- 2) 2 glycerol-P \rightarrow 2 dihydroxyacetone-P (+ 4 ATP).
- 3) 2 dihydroxyacetone-P \rightarrow 1 glucose (spontaneous).
- 4) 1 glucose \rightarrow 6CO₂ + 6H₂O (+ 36 ATP)
- Net 38 ATP (or 19 ATP/mole of glycerol).

3. The Energy Content of Lipids

A. A complete oxidation of fat yields 2.25 x more energy vs carbohydrates!

B. e.g., Tripalmitin vs. starch:

- 1) Tripalmitin (806 g/mole):

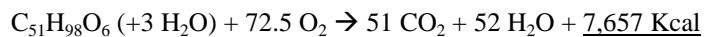

Glycerol	19 ATP
Palmitate	
Phosphorylation	- 2 ATP
7 cleavages x 5 ATP	+ 35 ATP
8 acetyl CoA x 12 ATP	+ 96 ATP
Net (129 ATP x 3)	387 ATP

Total **406 ATP**

- 2) Starch (162 g/mole, glucose basis):

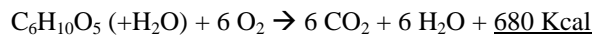

Glycolysis	10 ATP
Phosphorylation	- 2 ATP
NADH \rightarrow mitochondria	- 2 ATP
Net	6 ATP

Oxidation of 2 pyruvate	6 ATP
2 acetyl CoA x 12	24 ATP

Total **36 ATP**

- 3) Based on "gross energy:"

- a) 7,657 Kcal \div 806 g = 9.5 Kcal/g of fat.
- b) 680 Kcal \div 162 g = 4.20 Kcal/g of carbohydrate.
- \therefore 9.5 Kcal \div 4.20 Kcal = **2.26**

- 4) Based on "ATP production:"

- a) 406 ATP \div 806 g = 0.504 ATP/g of fat.

- b) $36 \text{ ATP} \div 162 \text{ g} = 0.222 \text{ ATP/g}$ of carbohydrate.
 $\therefore 0.504 \text{ ATP} \div 0.222 \text{ ATP} = \mathbf{2.27}$

4. Fatty Acid Synthesis

- See some references on the subject [e.g., Martin et al. (1983) & Mayes (2000) in "Harper's Biochemistry"]

A. Elongation pathways (2-C unit at a time):

- 1) Uses acetyl-CoA & NADH or NADPH for reduction in the mitochondria.
- 2) Uses malonyl-CoA & NADPH in the microsome.

- Both are modifications of the β -oxidation sequence. Also, can go through shortening by a sequential removal of 2-C units!

B. Some dietary lipids:

- 1) Are directly incorporated into the body fat with no loss of heat . . . Assuming adequate energy intake, i.e., dietary lipids are not necessary as a source of energy.
- 2) Thus, more efficient vs synthesis from CH_2O or others via acetyl-CoA, which results in a loss of some heat.

C. Extramitochondrial system for de novo synthesis:

- 1) Found in a soluble (cytosol) fraction of many tissues, e.g., liver, kidney, brain, lung, mammary gland, adipose tissue, etc.
- 2) Major products - Palmitic acid in liver & adipose tissues, and short-chained FA in the mammary gland.

BROWN ADIPOSE TISSUE

1. In General

- A.. A unique adipose tissue located near & around the spinal cord, thoracic organs and kidneys - Localized around some important/vital organs?!
- B. Characteristics? - A reddish-brown in color & has a well-developed blood supply & high contents of mitochondria and cytochromes.
- C. Metabolized within the brown fat tissue itself:
 - 1) A poor coupling of oxidative phosphorylation.
 - 2) FA oxidation with little ATP formation, and much of energy is released as "heat."
 - 3) e.g., "Exposure to cold environment?" - Nerve impulses can lead to release of norepinephrine \rightarrow activate lipase present in adipose cells \rightarrow hydrolyze TG to FA and

glycerol → ↑ oxygen consumption and ↑ the temperature of the tissue, and warming the blood passing through!

2. Importance?

- A. May be important when generating heat is necessary/crucial.
- B. Examples? - Newborn animals, exposure to cold, arousal from hibernation, etc., i.e., the need for "Non-Shivering Thermogenesis!?"
- C. Brown adipose tissue and "diet-induced thermogenesis?"
 - 1) Present in normal individuals and responsible for "diet-induced thermogenesis," which may account for some people can continue to eat and "not get fat!?"
 - 2) Brown adipose tissue is reduced or absent in obese individuals!

VITAMIN E AND SELENIUM INTERRELATIONSHIPS

1. Introduction

- A. Over the years, researchers observed a strong relationship between polyunsaturated fatty acids or PUFA and vitamin E, i.e., ↑ vitamin E requirement with ↑ dietary PUFA.
 - 1) e.g., Effect of linoleic acid intake on vitamin E requirement (rats) - Redrawn from Jagar, 1972. Ann. NY Acad. Sci. 203:199.
 - 2) Why?
 - a) ↑ in PUFA → ↑ peroxidation of lipids/fatty acids, thus, need for more vitamin E (antioxidant)
 - b) Plus, normal "oxidative" metabolism - Unstable, highly reactive, toxic forms of oxygen, i.e., free radicals, superoxide ions, hydrogen peroxide, lipid peroxides, etc.
 - c) Furthermore, "free radicals" can increase via heavy pollution, cigarette smoking, excessive alcohol, radiation, trauma, infections, etc.

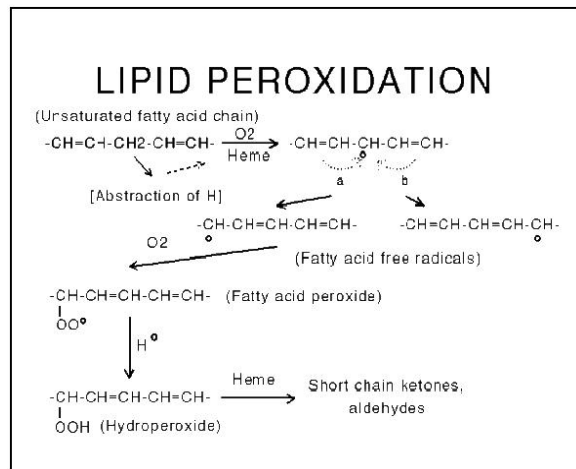
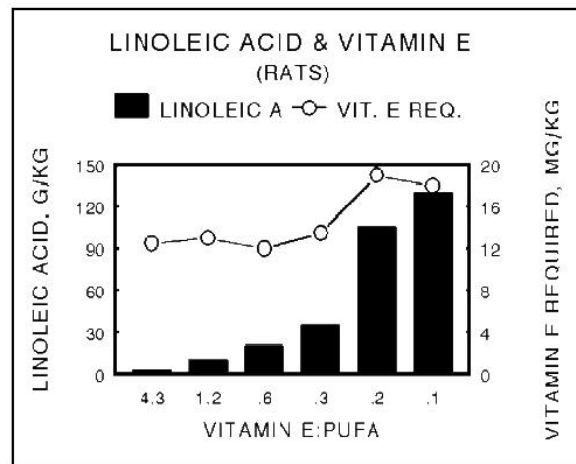

- Thus, need "antioxidants," and the most important ones? - Vitamin E & Se!?

B. Lipid peroxidation: (See the diagram)

- 1) Polyunsaturated FA are highly susceptible to an attack by free radicals and others generated during the metabolic process!
- 2) Lipid peroxidation either by abstraction of H or by addition of OH• (hydroxy radicals).
- 3) Highly reactive intermediates can attack other fatty acids, leading to chain reactions!

C. Polyunsaturated lipids can exacerbate many vitamin E deficiency symptoms.

D. Selenium & synthetic antioxidants have been implicated in the "PUFA-vitamin E relationships:" (Mcdowell, 1989; AO = antioxidant)

Disease	Animal	Tissue	Prevented by			
			E	Se	AO	S-AA
Reproductive failure:						
Embryonic degeneration						
Type A	Rat, hamster, hen, mouse, turkey	Vascular system	X		X	
Type B	Cow, ewe		^a	X ^b		
Sterility (♂)	Rat, guinea pig, hamster, dog, rabbit, monkey	♂ gonads	X			
Neuropathy	Chick, human	Brain	X		X	
Liver, blood, brain, capillaries, pancreas:						
Necrosis	Rat, pig	Liver	X	X		X
Fibrosis	Chick, mouse	Pancreas		X		
Erythrocyte hemolysis	Rat, chick, human, dog, monkey	Erythrocytes	X		X	
Plasma protein loss	Chick, turkey	Serum albumen	X	X		
Anemia	Monkey	Bone marrow	X		X	
Encephalomalacia	Chick	Cerebellum	X		X	
Exudative diathesis	Chick, turkey	Vascular system	X	X		
Kidney degeneration	Rat, mouse, mink, monkey	Kidney tubular epithelium	X	X		
Steatitis (ceroid)	Mink, pig, chick	Adipose tissue	X		X	
Depigmentation	Rat	Incisors	X		X	
Nutritional myopathies						
Muscular dystrophy	Rabbit, monkey, guinea pig, duck, mouse, mink, dog	Skeletal muscle	X		?	
White muscle disease	Lamb, calf, kid, foal	Skeletal & heart muscles	^a	X ^b		
Type C	Turkey	Gizzard, heart	^a	X		
Type D	Chicken	Skeletal muscle	X			X
Retinopathy	Dog, monkey, rat	Epithelium	X			
Dermatosis	Dog	Skin				
Immunodeficiency	Dog, chick, pig, mouse, sheep	Reticuloendothelial	X	X		

^aNot effective if severely deficient in Se.

^bWhen added to diets low in vitamin E.

2. Vitamin E & Selenium as Biological Antioxidants

A. Vitamin E & Se are both important as biological antioxidants.

- Vitamin E & Se inter-relationship - Redrawn from Nesheim et al., 1977.

B. Oxidative metabolism produces highly reactive form of oxygen that are highly toxic to organisms.

- Examples? - Superoxide ion, hydroxy radical, hydrogen peroxide and lipid hydroperoxides (UFA + O₂).

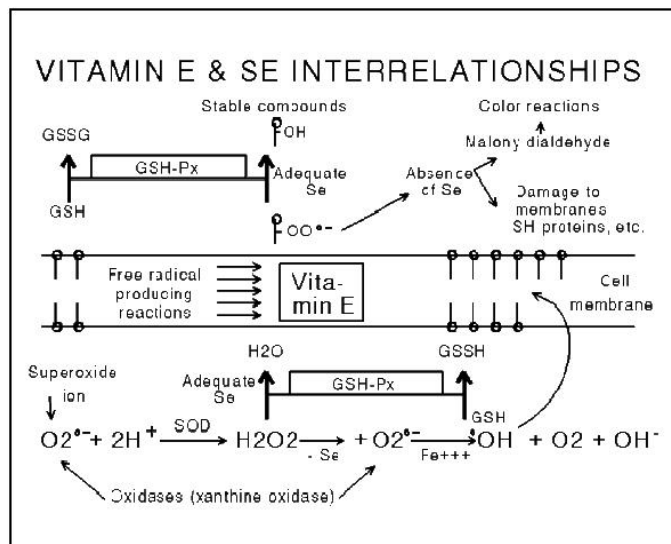

C. Vitamin E prevents formation of free radicals, which stimulate production of highly-reactive products, within the membrane of cells and organelles.

- Thus, the "First Line" of defense against peroxidation!

D. Glutathione peroxidase, which contains Se, eliminates and(or) and prevents formation of peroxides within the cellular interior or cytosol of cells.

- Thus, the "Second Line" of defense (i.e., destroys peroxides after formation)!

3. Interdependence of Vitamin E & Selenium

A. Se spares Vitamin E at least in 3 ways:

- 1) Maintains the integrity of pancreas & allows normal lipid metabolism (including metabolism of vitamin E).
- 2) As an integral part of glutathione peroxidase, reduces vitamin E required to maintain the integrity of cell membranes.
- 3) May aid in retention of vitamin E in plasma (mechanism, unknown!).

B. Vitamin E reduces the Se requirement by:

- 1) Maintaining body Se in an active form, or preventing its loss.
- 2) Preventing a chain-reactive autoxidation of the membrane, thus inhibiting formation of hydroperoxides, which ↓ the needs for Se-containing glutathione.

VITAMIN E

1. Introduction

A. General: (See Maynard et al., 1979, McDowell, 1989 & others)

- 1) Observed in the early 1920s that semi-purified diets containing all "known" vitamins supported growth/health of animals, but failed to support reproduction.
 - e.g. in mid to late 1930s - Fetal death/resorption & degeneration of germinal epithelium of testes in rats occurred unless a diet was supplemented with small amounts of wheat germ, dried alfalfa leaves, fresh lettuce & others.
- 2) About the same time (early 1930s) - Feeding similar semi-purified diets produced encephalomalacia in chicks, and muscular dystrophy in guinea pigs, rabbits & ducklings.
 - Demonstrated some years later that vitamin E deficiency was also responsible for these disorders!
- 3) In 1922, Evans & Bishop discovered an unknown dietary factor:
 - a) Its inadequacy resulted in the fetal resorption.
 - b) Known at that time as a "factor X."
 - c) Sure (1924) & Evans (1925) proposed the name "vitamin E."
- 4) By 1944, it has been established that a multiplicity of clinical signs occur in animals suffering from vitamin E deficiency.
 - e.g., in addition to reproductive disorders, three distinctive diseases, (1) exudative diathesis, (2) encephalomalacia & (3) muscular dystrophy, have been documented in chicks.

B. Structure, properties, and assay

- 1) Alpha-tocopherol is the most widely distributed vitamin E-compounds in nature & has a greatest biological activity.
- 2) "Tocopherol" - Greek words *tokos* ("offspring/ childbirth") and *pherein* ("to bring forth")!
- 3) Unit of activity:

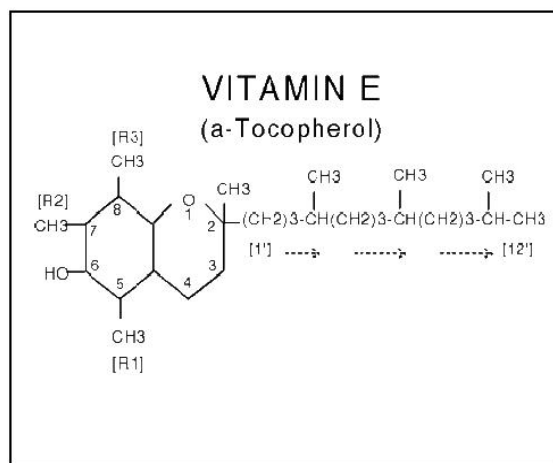

- a) 1 IU of vitamin E = 1 mg of dl- α -tocopherol acetate (synthesized).
 b) 1 IU of vitamin E = 0.67 mg of d- α -tocopherol acetate (extracted).
- 4) Natural vitamin E - Easily destroyed by oxidation, and oxidation is accelerated by heat, moisture, rancid fat & trace minerals (especially by Cu & Fe).
- 5) Tocopherols: (McDowell, 1989)

Tocopherol	R ₁ (5)	R ₂ (7)	R ₃ (8)
Alpha	CH ₃	CH ₃	CH ₃
Beta	CH ₃	H	CH ₃
Gamma	H	CH ₃	CH ₃
Delta	H	H	CH ₃
Alpha tocotrienol ^a	CH ₃	CH ₃	CH ₃
Beta tocotrienol ^a	CH ₃	H	CH ₃
Gamma tocotrienol ^a	H	CH ₃	CH ₃
Delta tocotrienol ^a	H	H	CH ₃

^aSide chain double bonds at 3', 7' & 11' positions.

- The α -tocopherol is the most widely distributed in nature and the most important vitamin E compound!?
- 6) Assays - many methods have been introduced:
- a) Physical methods:
- Separation of tocopherols by column, paper or thin-layer chromatography, followed by a colorimetric reaction.
 - Laborious/time consuming & colorimetric reactions are often subject to interference from other compounds!
 - "HPLC" methods consisting an extraction, saponification & chromatography offers a possibility of combining rapid analysis with separation of tocopherols from interfering substances.
- b) Biological methods:
- The "IU" have been established based on the most common biological assay, "rat fetal resorption tests."
 - Biological variations are inherent in a bioassay - e.g., effects of individuals, families, strains, species, management, environment, etc.

C. Specific function as an antioxidant

- Involved in reversible oxidation-reduction reactions.

- 2) Specifically, donate H to fatty acyl radical and others.
- 3) In the process, α -tocopherol becomes α -tocopheryl quinone, which can be excreted or lost from the body.
- 4) With some reducing agents (e.g., vitamin C), it can be converted back to α -tocopherol, and can participate in another reaction.

2. Metabolism

A. Absorption & transport:

- 1) "Absorption" - Primarily via the lymphatic system where they are transported as a lipoprotein complex, i.e., related to fat digestion, \therefore facilitated by bile & pancreatic lipase.
- 2) "Absorption site" - from the medial small intestine or SI in both nonruminants & ruminants, and not absorbed from the large intestine or LI in humans.
- 3) "Absorption rate" - a recovery rate of the vitamin in the feces ranges from 65 to 80% in humans, rabbit & hen (25% in chicks?), but the proportion of the vitamin (unabsorbed & secreted into the GI tract via bile) has not been established well.
- 4) Circulating vitamin E:
 - a) Lymph - nonspecifically bound to very low-density lipoprotein or VLDL (distributed throughout the VLDL particles), and then to the general circulation.
 - b) Plasma - no specific carrier in plasma, \therefore probably transported with both high-density lipoprotein or HDL & low-density lipoprotein or LDL (in the globulin fraction), and also with erythrocytes.
- 5) Tocopherols:
 - a) Can be passed through placental & mammary barriers, thus dietary status of the female can influence store of the young at birth (& thereafter via milk).
 - b) But, < 2% of dietary vitamin E can be transferred from feed to milk, i.e., a limited transfer!

B. Storage & excretion:

- 1) Vitamin E is stored throughout body tissues, with the highest in the liver (but only a small fraction of total body stores).
 - According to some, the adrenal gland & pituitary had the highest levels on the wet wt basis.
- 2) Unlike vitamin A, less body stores are available for a period of low dietary intake - e.g., 10-30 $\mu\text{g/g}$ in most tissues & 250 $\mu\text{g/g}$ in the adrenal gland of rats (wet wt basis).
- 3) The most common reaction that α -tocopherol undergoes is oxidation, which occurs readily in UFA, \therefore stores are depleted rapidly by PUFA present in tissues.

- The rate of vitamin E disappearance is proportional to the intake of PUFA!
- 4) Fecal elimination is the f route, and fecal tocopherol arises from:
 - a) Incomplete absorption.
 - b) Secretion from intestinal cells back into the lumen.
 - c) Desquamation of intestinal epithelia.
 - d) From the biliary route.
 - 5) Urinary excretion - only small amounts ($\approx 1\%$), but may \uparrow with a higher intake.
 - 6) Skin - according to some, might be a significant route of excretion.

3. Other Functions

A. Membrane structure

- 1) May be involved in formation of structural components of membranes, and perhaps increasing the stability.

- "Interaction between tocopherol & PUFA in a biological membrane:" (Adapted & redrawn from Diplock, 1985)
- May stimulate prostaglandin synthesis by increasing the conversion of linoleic to arachidonic acid, and preventing the peroxidation of arachidonic acid.

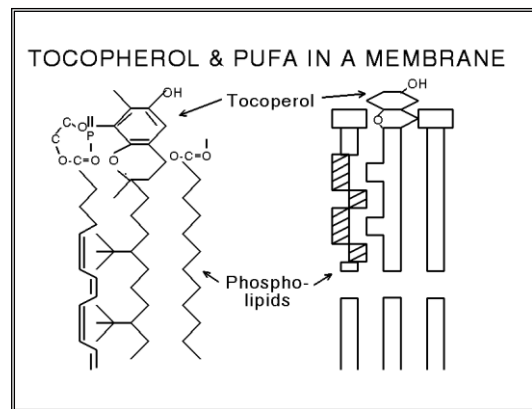

B. Inhibit platelet aggregation by increasing the synthesis of PGI₂. "Platelet aggregation" & vascular diseases?

C. May optimize the immune system:

- 1) Involved in the protection of leukocytes and macrophages during phagocytosis.
- 2) Stimulates antibody production.
- 3) Some examples?
 - a) Effects of vitamin E and(or) Se injections on serum IgG in piglets : Hayek et al., 1989. J. Anim. Sci. 67:1299.
 - b) Vitamin E natural killer cell activity in rats: Moriguchi et al., 1990. J. Nutr. 120:1096.
- 4) High-vitamin E:
 - a) \uparrow activity of natural killer cells.
 - b) Augment responses of splenocytes to mitogens.

- c) ↑ alveolar macrophage function via macrophage-activating factor produced by lymphocytes.
- Many investigations with other species demonstrated similar results, even though the magnitude & type of responses were different.

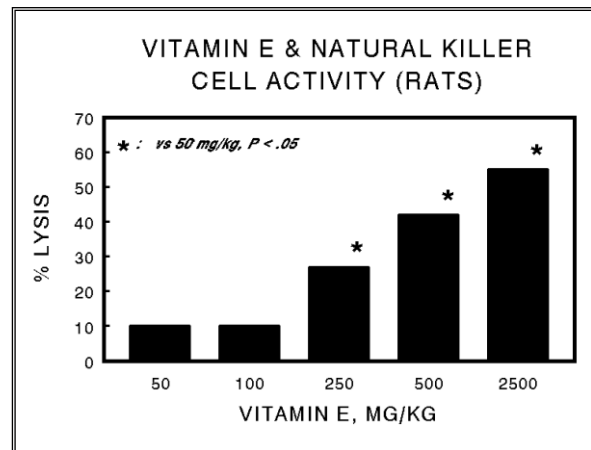
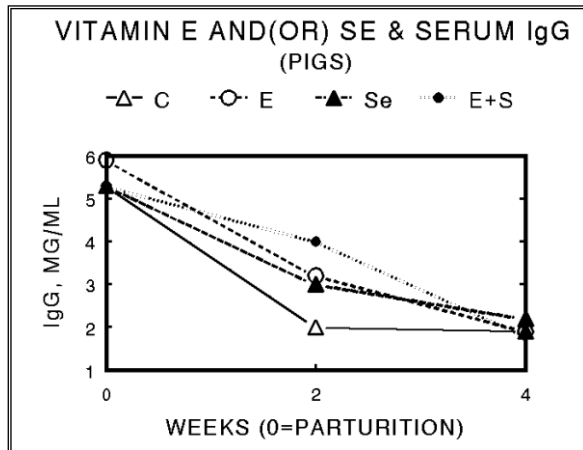

- D. May be involved in oxidation-reduction reactions - Possibly a cofactor in cytochrome reductase portion of NAD oxidase & succinate oxidase systems?
- E. May be involved in others such as:
 - 1) Normal phosphorylation reactions.
 - 2) Synthesis of ascorbic acid.
 - 3) Sulfur AA metabolism.

4. Deficiency

- A. Signs differ widely among species, and even within species.
- B. Muscular dystrophy," which occurs worldwide, is the only common syndrome among species.
- C. Specific diseases - please see "Vitamin E and Se Deficiency Diseases."

5. Requirements and Sources

A. Requirements: (NRC & RDA)

Animal	IU/kg or mg/d
Swine: (NRC, 1998)	
3-10 kg	16
10-120 kg	11
Sows/boars	44
Poultry: (NRC, 1994)	
Immature chickens	4.7-10
Laying hens	4-6

Broilers	10
Turkeys, growing	10-12
Turkeys, breeding	25
Horses (NRC, 1978)	233 µg/kg BW
Fish: (NRC, 1993)	
Channel cat fish, rainbow trout, pacific salmon & tilapia	50
Common carp	100
Beef cattle (growing)	15-60
Dairy cattle (milk replacer)	300
Others such as mink, cat, dog, rabbit, fish, rat	22-40
Humans, mg/d:	
Infants-children	3-7
Males & females	8-10
Pregnant/lactating	10-12

B. Sources - α -tocopherol content of feedstuffs (ppm): (McDowell, 1989)

Source	Mean	Range
Alfalfa, dehy	73	28-121
Barley	36	22-43
Dried brewers' grain	27	17-48
Corn	20	11-35
Animal fat	8	2-16
Fish meal	17	8-31
Meat & bone meal	1	1-2
Milo	12	10-16
Soybean meal	3	1-5
Wheat	11	3-15
Beef	6	5-8
Butter	24	10-33
Chicken	3	2-4
Eggs	11	8-12
Fish/shrimp	9	4-19
Pork	5	4-6
Brown rice	13.5	13-14

6. Supplementation

A. Example in pigs - Dietary vitamin E & sows/piglets^a (Mahan, 1991. J. Anim. Sci. 69:2904.)

Item	Vitamin E, IU/kg				
	0	16	33	66	
No. of pigs/litter:					
Birth	9.85	10.87	11.20	10.04	NS
Weaning	6.73	7.00	7.88	8.14	NS
α -tocopherol, µg/mL:					
Sow serum (d 28)	0.40	0.78	1.45	1.83	Ln

Colostrum	2.72	4.34	7.75	7.01	Ln
Milk (d 28)	0.44	0.77	1.29	1.67	Ln
Pig serum (birth)	0.05	0.10	0.15	0.16	Ln
Pig serum (d 28)	0.65	1.15	1.33	2.36	Ln
Post-weaning pig weight gain (0-28 d), g/d	375	346	332	329	

^aNS = not significant; Ln = linear ($P < 0.05$).

- Their conclusions/implications:
 - a) < 16 IU/kg of vitamin E is inadequate, which may result in a small litter size, sowagalactia, and also increase in pig mortality during the first week after birth.
 - b) Vitamin E can transverse the placental tissue, but rate is low - 0.142, 0.224, 0.241, and 0.305 $\mu\text{g/g}$ for 0, 16, 33, and 66 IU supplemental vitamin E/kg, respectively.
 - c) Mammary transfer, therefore, seems to be more effective means to provide α -tocopherol to nursing pigs, but, the importance of \uparrow vitamin E status of the fetus before birth (or even after birth) has not been evaluated.

B. Possible reasons for the high incidence of vitamin E/Se deficiency in swine in recent years:

- "Naturally occurring" vitamin E-Se deficiencies in swine were not reported until the late 60's, but became widespread in the 70's!
 - 1) \uparrow use of confinement - no access to pasture/forages.
 - 2) Low Se content in feeds (primary grains) produced in the midwestern U.S.
 - 3) \uparrow use of solvent-extracted protein supplements, which is low in vitamin E.
 - 4) A restricted-feeding practice for sows.
 - 5) Loss of vitamin E/Se via processing/storage of grains - e.g., drying, high-moisture grains, etc.
 - 6) Selection for meatier-type pigs, which may influence the requirement.
- Many of these factors also apply to other species, especially for poultry!
- For ruminants, vitamin E/Se contents in the roughage & dryness of ranges/ pastures are important considerations!

C. Commercial α -tocopherol supplements - Commonly used forms:

Forms	IU/mg
dl- α -tocopheryl acetate	1.00
dl- α -tocopherol	1.10
d- α -tocopheryl acetate	1.36
d- α -tocopherol	1.49
dl- α -tocopheryl acid succinate	0.89
d- α -tocopheryl acid succinate	1.21

- Available in various forms - powders, beadlets, mixed with gelatin, sugar, gum, dextrin, etc.

D. Ruminant species:

- 1) For grazing animals, an oral dose or intramuscular injection (in combination with Se) may be more effective in many instances.
- 2) A common practice in some ranchers to inject newborn calves with a mixture of vitamin E & Se.
- 3) Supplementation of the dairy calf (provide \approx 125-250 IU/d) or weanling calf (200-400 IU/d) diets with vitamin E has been shown to improve performance.

7. Toxicity

- A. Compared with vitamins A & D, vitamin E is relatively nontoxic, but not entirely devoid of adverse effects.
- B. Adverse effects on animals include \downarrow growth, \downarrow hematocrit, \uparrow prothrombin time, \uparrow requirements for vitamin D & K, \downarrow plasma Ca/P, \downarrow calcification & bone ash, \uparrow plasma TG, phospholipids & cholesterol, \downarrow hepatic storage of vitamin A, etc.
- C. Adverse effects on humans include creatinuria, fatigue, depression, hypoglycemia, hypertension, prolonged prothrombin time, etc.
- D. "Upper safety levels" - 1,000 to 2,000 IU/kg of diet or 75 IU/kg BW? (Based on limited data from rats, chicks, and humans.)

VITAMIN E AND HUMAN HEALTH

- *References - Various VERIS (Vitamin E Research & Information Service, LaGrange, IL) publications.*

1. Antioxidants & Aging/Cancer

- A. "Free radicals" - Highly unstable substances produced via metabolism & also from exposure to certain environmental factors (dietary components, smog, radiation, etc.).
- B. One suggestion for aging - Free radicals damage body cells and cause pathological changes associated with aging, and this process is gradual & irreversible!?
- C. Cancer:
 - 1) "Cancer" - Probably the result of external factors combined with a hereditary disposition for cancer.
 - 2) Normally, worn-out/injured tissues are replaced and(or) repaired.
 - 3) Often, cells change to a precancerous stage, but body's immune system detects & destroys abnormal cells.
 - 4) Occasionally, certain cells undergo changes without detection by the immune system, which can lead to "uncontrolled" growth & spread.
 - 5) Vitamin & Se Recommendations?

D. Free radical related damages:

- 1) Oxygen containing free radicals readily attack PUFA in cell membranes via peroxidation (a chain reaction).
- 2) Unless free radicals are neutralized, they can cause considerable damage to the structure & functions of cell membranes.

E. Vitamin E:

- 1) Inhibits accumulation of damaging free radicals. (Vitamin A, β -carotene & vitamin C are also antioxidants.)
- 2) Enhances the body's immune response (defense against cancer).
- 3) Protects vitamin A & spares Se.
- 4) Inhibits conversion of nitrites (present in smoked, pickled & cured food) to nitrosamines (strong tumor promoters) in the stomach.

2. Protection Against Air Pollution Damages

- A. Nitrogen dioxide & ozone (most damaging!) can generate unstable free radicals.
- B. Vitamin E traps & neutralizes free radicals more effectively than others in the lung.

3. Optimal Immune System

- A. Immune response initiation is considered to take place at the cell membrane level.
- B. Has stabilizing & regulatory effects on cell membranes to maintain optimal cell function. (via effects on free radicals!)

Vitamin & Se Recommendations for Cancer Prevention				
<i>Antioxidant</i>	<i>RDA</i>	<i>Recommendations</i>	<i>Toxic levels</i>	<i>Factors ↑ requirements</i>
Vitamin E	10-20 IU	200-800 IU	Negligible at < 1200 IU	High PUFA intake, smog, smoking
Vitamin A	5,000 IU	12,500 IU	Limited: 25,000 IU, chronic; > 300,000 IU, acute	Smoking
Vitamin C	60 mg	1,000 mg	Negligible at 1-2 g	Stress, oral contraceptives, smoking
Selenium	None	50-200 μ g	Potentially toxic at > 200 μ g	Aging, high PUFA intake, smog, heavy metal contamination

- C. Vitamin E supplementation - \uparrow immune response to antigen, stimulates production of antibody-producing lymphocytes, and \uparrow antibody production.
- D. Modulates synthesis of prostaglandins - "PG" are important regulators of immune responses and other host defenses, i.e., \uparrow PG is immunosuppressive, and vitamin E may prevent infection-induced \uparrow in PG.

- Optimal concentrations for the immune function in most animal studies range from 180 to 360 mg/kg, which are at least 3 to 6 times higher than those concentrations found in animal diets!

4. Neurological Role

- A. Detrimental effects of vitamin E deficiency on nervous & cardiac systems & skeletal muscle have been known for years.
- B. Identification of a chronic deficiency in progressive neurological syndromes in children & adults is much more recent. (Mechanisms are unknown, but probably associated with free radical damages to cell membrane of nerve & muscle tissues.)
- C. Beneficial effects of vitamin E supplementation on some neurological disorders - Tardive dyskinesia, Alzheimer-like dementia, Parkinson's disease, etc.

5. Exercise

- A. The body takes in & utilize oxygen at a higher rate during exercise.
- B. A higher rate of lipid peroxidation with higher degrees of exercise? Thus, vitamin E needed to prevent free radical-related tissue damage may increase during strenuous exercise!

6. Other Effects of Vitamin E (Bosco, 1989)

- A. Heart disease - Vitamin E has been used in a treatment for more than 30 yr, but still highly speculative!
- B. Human sexual potency or libido (aphrodisiac?) - Obviously, a deficiency will adversely affect a person's sex life, but ... a "sex vitamin???"
 - Vitamin E can affect so many systems in the body such as ↑ in production of sex hormones, PG, etc., it might be the "sex vitamin" after all!
- C. "Premenstrual syndrome" - 150 to 600 IU ↓ PMS symptoms (nervous tension, moodiness, anxiety, fatigue, etc.) in one study & related to PG synthesis?
... , etc.

SELENIUM

1. Introduction

A. General

- 1) Clearly established experimentally that Se in grains, grasses, and weed was toxic to animals in the early 1930s!
- 2) Why are we concerned about Se?
 - a) Can be toxic at very low concentrations!
 - b) Highly absorbable & readily transmissible - e.g., Placenta to fetus, mammary glands to milk, hens to eggs, etc.

- c) Plants can absorb enough to cause the toxicity in animals!
- B. The early interest in Se was in its role as a toxic element:
- 1) Did You Know?

"The battle of "Little Big Horn" in 1876. The U.S cavalry commanded by General George A. Custer had a 3-day forced march before reaching the Little Big Horn in Montana. Forages in that region contain toxic levels of Se. The horses were hungry since they had little grazing time during the march, so they avidly consumed the toxic plants and became sick. Obviously, they were unfit for ensuing battle, and thus were a factor in defeat. Also, a relief expedition failed to reach the beleaguered troops of General Custer in time to provide needed support. The officer in command of that expedition wrote in his official report that a peculiar sickness affected his horses, and was responsible for the delay." (McDowell, 1989)
 - 2) Marco Polo's journal:

"... a poisonous plant . . . which if eaten by horses has the effect of causing the hoofs . . . to drop off . . ."
 - 3) An Army surgeon in the Nebraska Territory described similar signs in horses in 1857, and he termed it "Alkali" disease!
 - 4) Three types of toxicity:
 - a) Blind staggers type (with as low as 2-5 ppm?) - Wandering aimlessly, stumbling, impaired vision & signs of respiratory failure.
 - b) Alkali disease type (with as low as 2-5 ppm?) - Lameness, hoof malformation, loss of hair & impaired reproduction.
 - c) High levels (over 40 ppm) - Sudden death or severe distress (labored breathing, ataxia, abnormal posture, diarrhea, etc.).
- Possible mechanisms?
 - a) Inhibition of certain sulfhydryl enzymes?
 - b) A high concentration of selenite (+ 4) can have "prooxidative" effects?
 - c) Se-Met can be incorporated into protein, i.e., toxic effects may not be Se per se!?
 - Treatment? Generally, not effective! Removing animals from the "high-Se sources" may improve the condition with "normal" kidney!?
- C. Selenium as a nutrient:
- 1) Established as an essential nutrient in the late 1950's:
 - a) Investigators found that Brewer's yeast contained unidentified factor that prevented necrosis in rats and exudative diathesis in chicks.

- b) Three substances, vitamin E, cystine, and Factor 3, had been known to protect rats from fetal liver necrosis since 1949, but the role of Se in Factor 3 was not discovered until 1957! ["Cystine" is involved in glutathione synthesis, and selenocysteine in GSH-Px.]
- c) Se prevented: (1) liver necrosis in rats, (2) exudative diathesis in chicks, and (3) white muscle disease in ruminants . . . & others.
- 2) In the early 70s, Rotruck et al. (1973; Science 179:588) discovered that Se was an integral part of glutathione peroxidase.

2. Selenium Deficient Areas

- A. Selenium deficient areas of the US are much larger than those areas that are Se-toxic.
- B. Selenium in crops in relation to animal needs: (Redrawn from Maynard et al., 1979 & McDowell, 1992)
- Any soil containing > 0.5 ppm is potentially dangerous!
 - Se in water? - Widely distributed, but in low concentrations: fresh water, 0.2 to 10 µg/L, and sea water, 0.09 µg/L.

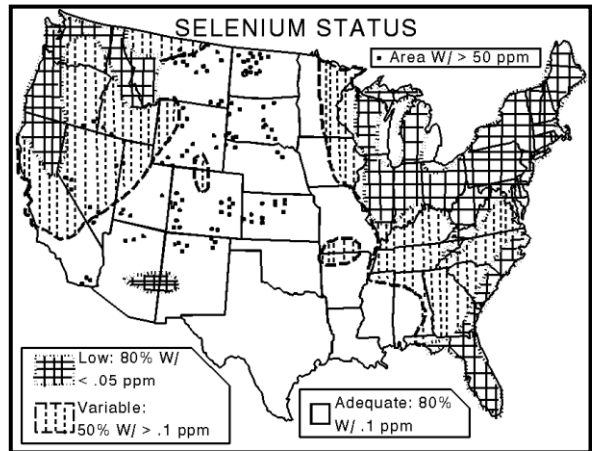

3. Function as an antioxidant?

A. Reaction?

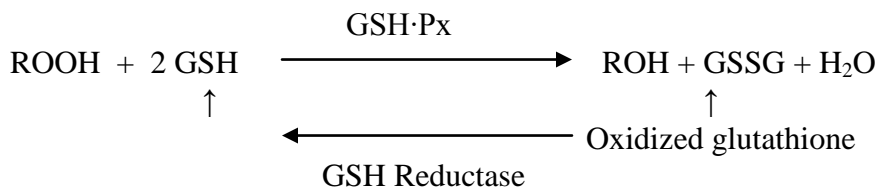

- B. The GSH-Px activity? - High in the liver, moderate in RBC, heart muscle, lungs, and kidney, and low in the GI & skeletal muscle.
- C. Four known GSH-Px in the body (Mahan, 2001):
- 1) Cellular GSH-Px - The most abundant and located in the cytoplasm of the cells where hydroperoxides from cellular metabolism are reduced via glutathione.
 - 2) Located in the cells of the intestinal tract - Reduces absorbed hydroperoxides.
 - 3) Located in the ECF or plasma - Reduces hydroperoxides esterified to phospholipids, as well as free hydroperoxides.
 - 4) Intracellular phospholipid hydroperoxide GSH-Px - Located adjacent to subcellular membranes preventing intracellular lipid peroxidation.-

4. Other Functions?

- A. May play a role in electron transport - e.g., isolated a selenoprotein that resembles cytochrome C) in heart & muscle, which was absent in Se-deficient animals.
- B. A specific selenoprotein in spermatozoa may serve as a structural protein for mitochondria, or as an enzyme.
- C. May play a role in RNA because Se can be incorporated into purine or pyrimidine bases.
- D. May have a role in prostaglandin synthesis & EFA metabolism.
- E. May be involved in the immune response.

e.g., Effect of dietary Se on IgG concentration in yearling & older ponies (mg/100 mL): (Knight & Tyznik, 1990. J. Anim. Sci. 68:1311)

Week	0.02 ppm	0.22 ppm
0	1,170	1,250
1	1,420	1,475
2	1,280	1,740
3	1,700	2,365
4	1,380	2,090
5	1,310	1,915

* Observed similar responses in whole blood Se & GSH-Px activity.

5. Absorption/Excretion

- A. Dietary concentrations/Se status of animals and the “form” affect the rate of absorption:
 - 1) Greater absorption in a deficient state.
 - 2) Organic compounds, selenide (- 2) & elemental Se (0) are absorbed less efficiently.
 - 3) Selenite (+ 4), selenate (+ 6) & selenomethionine are highly available sources.
- B. Absorption rate:
 - 1) Swine - No absorption at the stomach and first part of the SI, and the greatest absorption at the last part of the SI, cecum & colon. About 77% of oral Se was retained in one study!
 - 2) In rats, soluble Se compounds are efficiently absorbed from the GI tract (e.g., 92 & 91% for selenite & selenomethionine, respectively).
 - 3) In humans, apparent absorption of dietary Se ranges from 55 to 70%.
 - 4) Ruminants - Less efficient vs nonruminants (e.g., ~ only 30% in sheep) because Se may be reduced to insoluble compounds in the rumen .
- C. There seems to be no homeostatic control of Se absorption.
- D Excretion:
 - 1) Via urine, feces & exhalation (1° route in the Se toxicity).

- 2) Urinary excretion - 1° route in nonruminants & humans (excretion rate is closely related to dietary intake).
- 3) Fecal excretions - Contain unabsorbed dietary Se, small amounts of Se excreted via bile, pancreatic and intestinal secretions.
- 4) In general, ruminants excrete Se in the feces possibly because rumen microbes reduce Se to unavailable form, ∴ ↑ excretion in the feces.

6. Deficiency

- A. A sudden death - A prominent feature of the deficiency).
- B. Based on necropsy - e.g., Massive hepatic necrosis, edema in lungs, stomach submucosa, etc., paleness & dystrophy of the skeletal muscle (white muscle), and mottling and dystrophy of the myocardium (mulberry heart).
- C. Impaired immune response.
- D. Impaired reproductive performance & milk production.

7. Assessing the Se Status (Ullrey, 1987. J. Anim. Sci. 65:1712)

- A. Analysis of plasma or serum Se - Plasma or serum Se ↑ directly with ↑ dietary inorganic Se from deficient to adequate (0.1 to 0.3 ppm), and from > 0.3 to 0.5 ppm, plasma or serum Se ↑ until reaching a dietary level that ↓ feed intake.
- B. Analysis of whole blood Se:
 - 1) Whole blood Se levels are ≈ 10 to 50% higher vs plasma or serum because of higher Se contents in erythrocytes.
 - 2) Whole blood Se levels tend to follow a pattern in plasma or serum.
 - 3) 1° difference? - A tendency for a lag period in the Se response in whole blood vs serum or plasma possibly because of a relatively long half-life of erythrocytes.
 - Most of Se in red cells is incorporated during erythropoiesis.
- C. Assay of plasma or serum GSH-Px activity:
 - 1) Relatively low proportion of Se is associated with GSH-Px in rats.
 - 2) A very low GSH-Px activity in plasma of sheep, thus usually not recommended to use as a response criterion!
 - 3) The GSH-Px activity provides conclusions similar to plasma Se in a deficient to adequate region in rats.
 - 4) Above adequate - Poor correlations with dietary or plasma Se in rats, swine & cattle.
- D. Assay of whole blood GSH-Px activity:
 - 1) The GSH-Px activity in erythrocytes is higher than plasma in all species examined, ∴ consistently measurable.
 - 2) The GSH-Px activity has a high correlation with plasma Se in low-Se animals, but correlations may be poor in adequate to high dietary Se.

- E. Measurement of urinary Se excretion - Urinary Se as a proportion of intake ↑ remarkably when dietary levels exceed an apparent requirement.
- F. Analysis of Se in skeletal muscle:
 - 1) Dietary & skeletal muscle Se levels are directly related in animals consuming diets that are low to adequate.
 - 2) Samples obtained by biopsy, at necropsy or at slaughter can be used to assess Se status in cattle, sheep or swine.
- G. Se contents in animals (wet basis):
 - 1) Skeletal muscle (. . . animals apparently fed adequate diets) - Swine, 0.05 to 0.10 ppm; cattle, 0.04 to 0.14 ppm (0.50 ppm in one report); sheep, 0.06 to 0.24 ppm (0.85 & 1.56 ppm reported in two reports).
 - 2) Poultry - Chicks & poult fed deficient diets = ≈ 0.05 ppm (Scott & Thompson, 1971: Poul. Sci. 50:1742) & whole egg = ≈ 0.3 ppm (Latshaw, 1975: J. Nutr. 105:32).
 - 3) Plasma - 0.80 to 0.91 ppm in swine & 0.42 ppm in rats.

8. Requirements

- A. Must consider:
 - 1) Variations in the Se content of feedstuffs (i.e., geographic areas).
 - 2) Antioxidant levels in the diet (including vitamin E).
 - 3) In swine & poultry - Se status of dam influences the requirement for nursing/weanling pigs & chicks. (Selenium is readily transmissible through placental & mammary barriers, and also from hens to eggs!)
 - 4) The amount of supplemental Se permissible is regulated in the US [maximum of 0.3 ppm (FDA, 1987)] and also in Canada.
- B. Se requirements - Plasma glutathione peroxidase level is a reliable index of the Se status of pigs (also for poultry?):

Animal	mg/kg or ppm
Swine (NRC, 1998):	
3-10 kg	0.30
10-20 kg	0.25
20-120 kg	0.15
Sows/boars	0.15
Poultry (NRC, 1994):	
Immature chickens	0.10-0.15
Laying hens	0.05-0.08
Broilers	0.15
Turkeys	0.20
Horses, all classes (NRC,1989)	0.10
Fish (NRC, 1993):	

Channel catfish	0.25
Rainbow trout	0.30
Pacific salmon	Required, but not determined
Common carp & tilapia	Not tested

9. Amelioration of Se Toxicity?

- A. e.g., Effects of arsenical & cysteine on chicks fed diets supplemented with a toxic level of inorganic Se: (Lowry & Baker, 1989. J. Anim. Sci. 67:959)

Item	Gain, g/d	Gain:feed, g/kg	Liver Se, $\mu\text{g/g DM}$
Basal 269	662	0.8	
Basal + 15 mg/kg Se	109	458	14.9
Basal + Se + 14 mg As/kg	256	657	17.2
Basal + Se + 0.4% L-Cys	149	520	18.5
Basal + Se + As + Cys	254	671	17.4

- B. L-Cys (& its derivatives, which are commonly used to treat heavy metal toxicity) showed ameliorative activity.
- C. "As" compound totally corrected performance depressions, but it did not lower liver Se.
- Not in this research, but has been demonstrated in the earlier research that "As" increased biliary excretion of Se into the intestine.

CHOLINE

1. Introduction

- A. Is choline a vitamin?

- 1) Does occur in many foods along with other B complex factors.
- 2) But, does not entirely satisfy a strict definition of the vitamin:
 - a) Can be synthesized in the liver in a greater/adequate amount.
 - b) Found in the body in a large amount, and apparently functions as structural constituents rather than a catalyst of essential metabolic reactions.
 - Are these two facts enough to disqualify choline as a vitamin?
 - Then, how about niacin, vitamin C for many species & vitamin D?
- 3) According to recent research: (Bosco, 1989)
 - a) There are conditions in which the body does not synthesize an "adequate" amount of choline for all its needs.
 - b) Dietary choline may affect choline levels at various key point in the body.

B. General:

- 1) Isolated from the bile of pigs in 1849, and from an alkaloid of white mustard seed in 1852.
- 2) In 1929, isolated "acetylcholine," ∴ a recognition of its importance!
- 3) In 1932, found to be the active component of lecithin, which has been shown to prevent fatty livers in rats.
- 4) Later studies found that choline is involved in:
 - a) Both growth & prevention of perosis in poultry.
 - b) Prevention of a spraddle leg in swine.
 - c) Human conditions relating to the mobilization of liver lipids.

2. Structure, Properties, Assay

A. Structure of free choline, acetylcholine & lecithin: (Adapted & redrawn from McDowell, 1989)

B. Characteristics:

- 1) A colorless, viscid, strongly alkaline liquid that is notably hygroscopic.
- 2) Soluble in water, formaldehyde & alcohol.
- 3) Widely distributed in nature as free choline & acetylcholine, and also as more complex phospholipids & their metabolic intermediates.

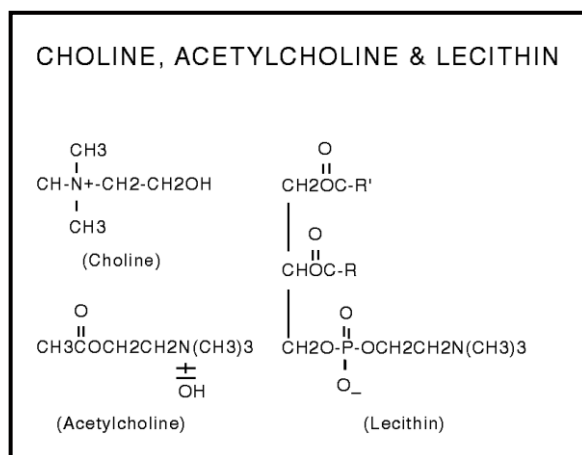

C. Analysis:

- 1) Complicated because it exists in various forms in biological materials, and compounds are rapidly hydrolyzed in biological tissues.
- 2) Enzymatic radioisotopic assay & gas chromatography provide high sensitivity & specificity, and have been used widely in recent years.
- 3) Others - microbiological assay, conversion of choline to acetylcholine in isolated tissues, growth assay, etc.

3. Metabolism

A. Metabolic pathway: (Adapted & redrawn from McDowell, 1989)

B. General:

- 1) Present in the diet 1° as lecithin with < 10% as either free base or sphingomyelin.

- 2) Released in the GI tract by digestive enzymes, and absorbed from the jejunum & ileum mainly by an energy- & Na-dependent carrier mechanism.
- 3) Only 1/3 of ingested choline is absorbed intact, and the rest is metabolized by intestinal microorganisms to trimethylamine, which is excreted in the urine between 6 & 12 h after consumption.
- 4) Less urinary excretion of trimethylamine if ingested as lecithin.

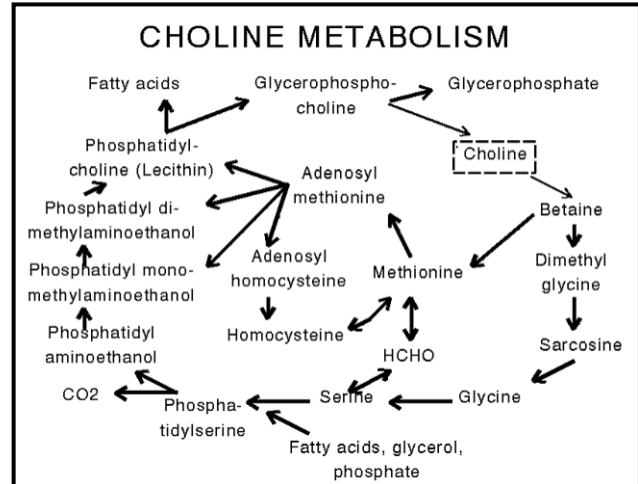

C. A rate limiting step in the synthesis for young birds?

- 1) Conversion of phosphatidyl amino ethanol to phosphatidyl monomethylamino ethanol!
- 2) Met or other methyl donors cannot spare choline.
- 3) After 8 wk or so, no problem or no deficiency signs, period!

D. Betaine supplementation?

- 1) Choline itself cannot act as a methyl donor, thus must be oxidized to betaine first.
- 2) Betaine performs the methylation function equal to or better than choline.
- 3) But, cannot prevent perosis, fatty liver, etc. without a precursor of choline such as mono- or dimethyl derivatives ethanolamine.
- 4) In recent years, some interest in using betaine (extracted from sugar beet?) to:
 - a) Reduce carcass fat and(or) change the "distribution" of carcass fat in broilers, fish, and pigs, but the results have been very inconsistent!
 - b) Perhaps, similar effects on humans, and there are a lot of products on the market! Many companies are promoting the use of "betaine hydrochloride!"

4. Functions

A. In lipid metabolism:

- 1) A component of phospholipids (important in the cell structure):
 - a) Phosphatidylcholine (lecithin) - A part of cell membrane, and also lipid transport moieties.
 - b) Sphingomyelin - Found in brain & nerve tissues.

- 2) Involved in phosphorylation and mobilization of long-chained FA from the liver, and in oxidation of FA in the liver.
 - Hastening a removal of lipids or ↓ deposition of lipids in the liver, thus referred to as a “lipotropic” factor!

B. Acetylcholine:

- 1) Released at the termination of parasympathetic nerves & involved in a transmission of nerve impulses from presynaptic to postsynaptic fibers.
- 2) e.g., acetylcholine released by the stimulation of vagus nerve slow down heartbeat, oviduct contraction, etc.

C. Source of labile methyl groups:

- 1) Aactive methyl groups: (Adapted & redrawn from McDowell, 1989).
- 2) A methyl group is important in the formation of methionine from homocystine, creatine from guanidoacetic acid, etc.

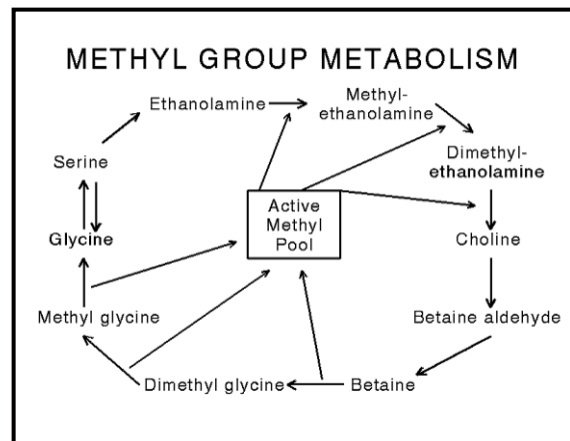

5. Deficiency

A. Signs in poultry:

- 1) Poor growth.
- 2) Perosis (slipped tendon) - Hemorrhages & puffiness of a hock joint, flattening of a joint, achilles tendon slips from its condyles and results in immobility.
- 3) Effect of choline on perosis in chicks? (Ketola & Nesheim, 1974. J. Nutr. 104:1484)

Choline, mg/kg	Incidence, %
0	54
300	0
600	0

- a) Perhaps, need phospholipids for a normal maturation of cartilage matrix of bones, thus choline has some beneficial effects?
- b) In mature birds, their synthetic rate might be sufficient to meet the requirement, but may have to supplement for a maximum egg production.

B. Signs in swine:

- 1) Poor growth & unthriftiness.
- 2) Poor conformation - Short-legged & pot bellied.

- 3) Lack of coordination - e.g., "Spraddle legs" in newborn pigs, which can be prevented by supplementation of choline to the sow diet. But, also genetics, folacin and(or) B₁₂ may be involved!
- 4) Fatty infiltration of liver.

5. Requirements

A. In general:

- 1) Requirements can be met by: a) dietary supplemental choline or from typical feedstuffs, and b) choline synthesis in the body.
- 2) Affected by:
 - a) Dietary Met (other principal methyl donor) level.
 - b) Folacin level - Folacin in formation of a labile methyl group from a formate C.
 - c) Vitamin B₁₂ level - B₁₂ in transfer of a methyl group to tetrahydrofolate.
 - d) Others - Dietary protein, lipids & carbohydrate, sex, growth rate, etc.

B. The effect of dietary choline supplementation - Example in pigs:

- 1) Starter, grower and finisher pigs showed - No beneficial effect of supplementation?!
- 2) For sow diets - May or may not have beneficial effects:

a) Stockland & Blaylock, 1974. J. Anim. Sci. 39:1113:

Added choline (ppm):	0	400	800
Farrowing rate, %	62	80	76
No. born 9.3	10.4	9.8	
Live pigs born	8.0	9.2	9.8
No. weaned	6.6	7.6	6.9
Piglets w/spraddle legs	17	7	10

b) Maxwell et al., 1987. J. Anim. Sci. 64:1044:

Item	No supplement	882 or 551 ppm
Litter size:		
At birth	10.65	10.69
At d 21	7.76	8.22
Litter weight (kg):		
At birth	13.17	13.33
At d 21	36.53	39.68
Spraddle legs:		
Litter w/one or more	8	10
No of pigs	11	12

* Total = 1,350 & 1,800 ppm for 551- & 882-ppm groups, respectively.

- (1) Some improvements in sow performance with choline supplementation.
 (2) No effect of choline on the incidence of spraddle legs.
- 3) No signs of toxicity reported in swine, but may reduce weight gain of pigs with 2,000 mg choline/kg - e.g., Southern et al., 1986. J. Anim. Sci. 62:992. (Weight gain data!)

Item	0	500	1,000	2,000	4,000	6,000
Weanling pigs:						
Exp. 1 & 2	721	696	720	684	-	-
Exp. 3	649	-	-	636	664	601
Weanling-finisher pigs:						
Exp. 4	757	-	-	701	-	-
Exp. 5	763	-	-	734	-	-
Grower-finisher pigs:						
Exp. 6	882	-	-	845	-	-
Exp. 7	777	-	-	802	-	-

C. Choline requirements:

Animal	mg/kg
Poultry (NRC, 1994):	
Immature chickens	470-1,300
Laying hens	875-1,310
Broilers	750-1,300
Turkeys, growing	800-1,600
Turkeys, breeding	1,000
Swine (NRC, 1998):	
3-5 kg	600
5-10 kg	500
10-20 kg	400
20-120 kg	300
Gestating sow & boar	1,250
Lactating	1,300
Horses (NRC 1978)	Microbial synthesis
Fish (NRC, 1993):	
Channel catfish	400
Rainbow trout	1,000
Pacific salmon	800
Common carp	500
Tilapia	Not tested
Adult beef cattle, sheep, goat & horse	Microbial synthesis
Cat	2,400
Growing dog	1,250
Humans	???

D. Sources: (McDowell, 1989)

Source	ppm (dry basis)
--------	-----------------

Alfalfa, dehy	1,370
Barley	1,177
Corn, yellow	567
Cottonseed meal	2,965
Fish meal, anchovy	4,036
Oats	1,116
Milo	737
Soybean meal	2,916
Wheat	1,053

- 1) Not enough information on the availability of choline in natural feedstuffs, but based on a chick assay, soybean meal & whole soybeans may contain 60 to 75% available choline.
- 2) Supplemental choline:
 - a) Choline chloride contains 86.8% choline (a 70% liquid or 25-60% dry powder).
 - b) Choline bitartrate contains 48% choline.

6. Toxicity

A. Signs:

- 1) Experimental animals - signs include excessive salivation, trembling, jerking, cyanosis, convulsion & respiratory paralysis.
- 2) Humans - signs include acute gastrointestinal distress, sweating, salivation and anorexia.

B. Upper safe levels: (Not enough data to make precise estimates!)

- 1) Swine – Have high tolerance for choline.
- 2) Chickens - twice the dietary requirement is safe, and adverse effects with > 2 times the requirement.
- 3) Dogs - adverse effects with 3 times the requirement.
- 4) Mice:
 - a) Oral choline chloride is relatively innocuous - LD₅₀ is 3,900 mg/kg BW.
 - b) But, more toxic when given i.v. - LD₅₀ is 53 mg/kg BW.

C. Excess supplemental choline (ppm) on weight gain of pigs (g/d): (Southern et al., 1986. JAS 62:992)

Item	0	500	1,000	2,000	4,000	6,000
Weanling pigs:						
Exp. 1 & 2	721	696	720	684	-	-
Exp. 3	649	-	-	636	664	601
Weanling-finisher pigs:						
Exp. 4	757	-	-	701	-	-

Exp. 5	763	-	-	734	-	-
Grower-finisher pigs:						
Exp. 6	882	-	-	845	-	-
Exp. 7	777	-	-	802	-	-

7. Choline for Humans (Bosco, 1989)

A. Choline & "Tardive dyskinesia?"

1) Tardive dyskinesia:

- a) Results of a derangement of nerve impulses caused by certain drugs commonly given to psychotic patients.
 - b) A loss of control over facial muscles resulting in involuntary grimaces, chewing, puckering & tongue protrusions.
- 2) High doses of choline (150-200 mg/kg BW) had beneficial effects without interfering with the effects of psychotic drugs.
- Also, some positive results have been observed in people suffering from Huntington's disease (similar to T. dyskinesia, but not brought on by drugs).

B. Choline & memory?

- 1) Alzheimer's disease - improved memory by 5 to 10 g choline/d.
- 2) Supplementation for normal, healthy people? - a single dose of 10 g choline improved the "memory" test (a serial learning & selective reminding) scores in college students & recent graduates ... So?

C. Others – Some beneficial effects on heart disease & cancer?

SUPPLEMENTAL DIETARY LIPIDS

1. Dietary Lipids in General

A. For nonruminant species in general

1) Before WW II:

- a) Primarily concerned about the quantity of feed.
- b) Fed many ingredients hoping to provide all the necessary nutrients. Some - not identified yet?

2) After WW II (. . . or during the WW II?):

- a) Perhaps, partly because of "scarcity," forced to standardize a feeding method/practice.
- b) That is, to provide energy & protein sources, and then supplement diets with "known" vitamin & mineral sources!?
- c) "Plant-based" diets?" Examples? - A corn-soy diets supplemented with some vitamin & mineral sources!

B. High-energy diets for poultry:

- 1) About 50-60 years ago, researchers (Univ. of Connecticut) observed that feed efficiency was improved by ↑ energy content of broiler diets.
- 2) Intensive research at many universities followed, and found that:

- a) There is a limit to the level of dietary energy that can be ↑.
- b) Beyond a certain level:
 - (1) Produced poor growth & feathering, and also reduced feed efficiency.
 - (2) Believed by many that high energy ingredients such as fats contained "toxic" factors.

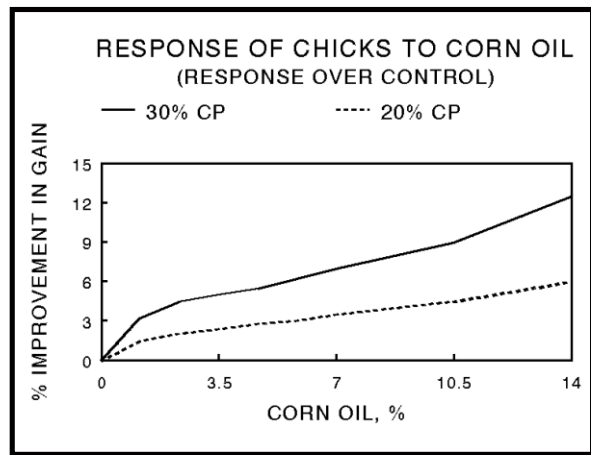

- 3) Around mid 50's, researchers discovered an importance of "quality & quantity" of dietary protein:
 - a) "Toxic effects" of high energy were overcome by simultaneous increase in dietary protein content (Donaldson et al., 1955, 1956, 1958. Poul. Sci. 34:1190, 35:1100, and 37:614.)
 - b) e.g., See Rand et al. (1958). Response of chicks to corn oil at two levels of protein. Poul. Sci. 37:1075.

- At the lower protein concentration, performance ↓ as dietary lipid ↑, but not at the higher protein concentration.

- 4) Subsequently, they found that growth rate, carcass fat, feed efficiency & feathering were influenced by manipulations of protein and energy ratios.

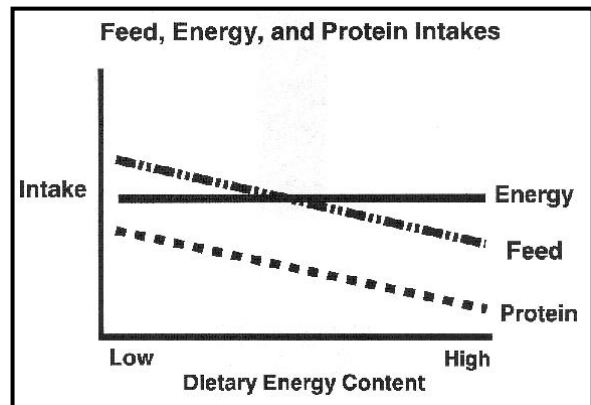

- a) Led to the concept of "Calorie to Protein Ratio!"
 - b) Simply, "as we increase the dietary energy content, we have to increase the dietary protein content simultaneously!" [See "Feed, energy, and protein intake"]
 - c) Reason? "Animals eat to satisfy their energy needs!"
- C. Lipostatic theory?
- 1) "Animals eat to satisfy their energy needs!" - True?
 - 2) Rats normally eat for calories rather than for flavor (Adolph, 1947. Am. J. Physiol. 151: 110).
 - 3) Lipostatic hypothesis (Kennedy, 1953. Proc. Roy. Soc. B. 140:578; 1961. Proc. Nutr. Soc. 20:58):
 - a) The body keeps its own energy balance sheet automatically, i.e., "fat," which is only the form that any significant amount of surplus energy can be stored.
 - b) "Fat" can provide "energy memory," and if fat stores are kept constant, energy balance should be preserved.
 - c) In the long term, the hypothalamus modifies the general level of "feed intake and bodily activity" in response to changes in body fat!
 - 4) Lipostatic theory and leptin?
 - a) "Satiety factor" that controls eating habit - Leptin?
 - b) Leptin:
 - (1) From the Greek word "leptos," meaning "thin."
 - (2) Produced primarily by fat cells, but also by the gut and placenta cells.
 - (3) Circulating in blood and act on different tissues, including the hypothalamus, skeletal muscle, and liver.
 - c) Weight loss and leptin?
 - (1) Mice with mutation on both genes (ob/ob mice) cannot produce leptin:
 - Unaware of when they have enough fat stores, thus, overeat & become obese.
 - (2) Injection of recombinant leptin can depress appetite and leads to weight loss in some studies, including human studies!
 - (3) Circulating leptin and body fat:
 - (a) Positively correlated without any mutation on their ob genes.
 - (b) Dieters tend to have a low concentration of leptin.
 - (c) Obese individuals have a high concentration of leptin, and have some sort of resistance to leptin, perhaps, via a "feedback loop!?"

(d) For everybody? - Three general types?

- (a) Not get obese, period!
- (b) Diet induced obesity? - Leptin may work for some but not for others.
- (c) Individuals with obese genes (e.g., homozygous for the ob mutation) - Leptin has therapeutic effect, i.e., can reduce body fat!

e) A subset of the population may be predisposed to obesity and environmental factors? - Leptin may be beneficial?

D. Energy density & energy intake:

- 1) Feed intake is largely determined by dietary energy content, i.e., animals generally adjust their voluntary feed intake to achieve a constant energy intake!
- 2) Voluntary feed and DE intake with varying nutrient (energy) density: [Cole et al., 1972. In: Cole (Ed.) Pig Production]

- The idea that “Animals eat to satisfy their energy needs?” The concept may work within a certain range of the energy density. But, outside of that range - ?

3) Feed and energy intakes in the pig and chick: (See the figure on “Feed & DE intake”)

- a) Chicks have a well controlled system for energy intake.
- b) But energy intake tends to increase with dietary addition of lipids in pigs:

- (1) This pig's propensity to over-consume energy may lead to its characteristic, “obesity?!” (The same is true for humans!?)
- (2) Also, this contributes to an unclear energy-protein relationship in swine.

C. Dietary lipids? Example in pigs:

1) Addition of lipids to swine diets:

- a) Extensively investigated over the years (started in the early 1950's).

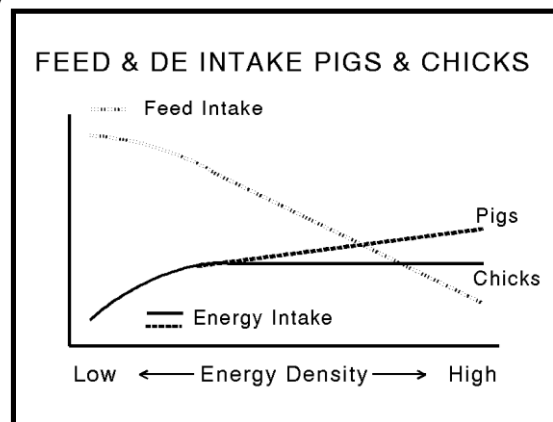
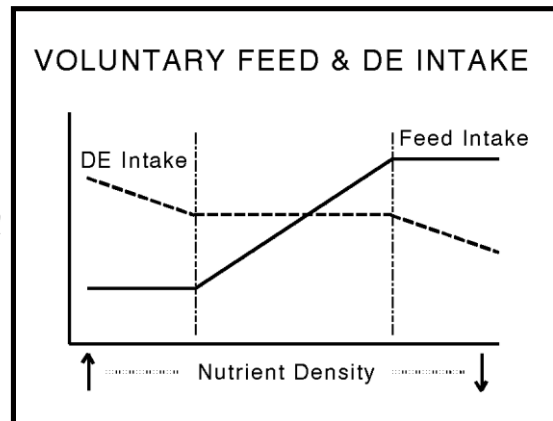

- b) Generally, improved feed efficiency, but inconsistent responses in weight gain and carcass fat.
 - c) The necessity of adjusting dietary protein in accordance with supplemental fat is still a matter of debate!
- 2) Possible reasons for conflicting results (. . . regarding the necessity of adjusting protein concentrations):

- a) Differences in the age of pigs.
- b) Differences in the type & levels of lipids used.
- c) "Protein sparing effect" of dietary lipids:
 - (1) Lipids are highly available energy source, and have beneficial effects on protein metabolism.
 - (2) Thus, less deamination of protein as a source of energy, i.e., lipids (& CH₂O) may provide enough substrates for the TCA cycle.
 - (3) Greater release of insulin (anabolic), which has beneficial effects on protein metabolism, with dietary lipids?

- d) Improve protein digestibility with dietary lipids.
- e) "Quantity and quality of protein used.
- f) Depressions in the rate of lipogenesis: (Allee et al., 1971. J. Nutr. 101:1415)

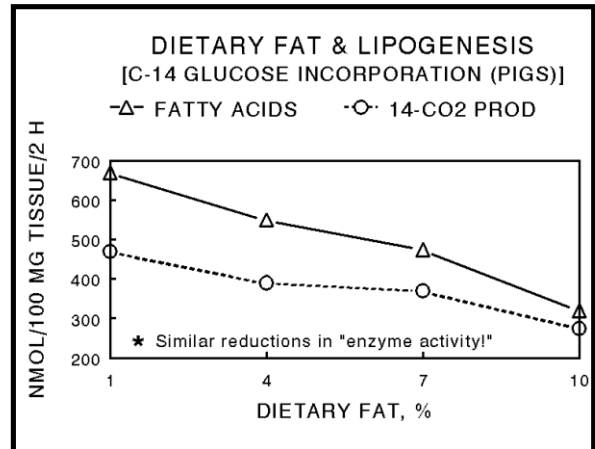

- (1) Also, decrease the activity of malic enzyme, citrate cleavage enzyme, etc.
- (2) A possible reason? - Free-FA or their CoA derivatives may inhibit acetyl CoA carboxylase, which is a limiting factor in lipogenesis!

- g) Alterations in the body composition.

D. Extra caloric effect:

- 1) The addition of fat improves the utilization of energy, and this increase in efficiency is referred to as "extra caloric" effect.
- 2) Quite often, greatly exceed its gross energy value - e.g., Estimated ME value of fat: (Jensen et al., 1970. Poult. Sci. 49:1697)

Age, wk	ME, Mcal/kg
8-12	9.92

12-16	8.96
16-20	10.11
20-24	11.69

* vs. GE = 9.4 to 9.5 Mcal/kg & assumed ME value = 7.72 Mcal/kg.

- 3) May be explained partly by:
- Synergism between saturated and unsaturated fatty acids.
 - Lower rate of passage of food, which may enhance nutrient digestion/ absorption.
 - ↓ energy expenditure for FA synthesis from CH₂O, i.e., direct deposition of lipids.
 - ↑ vitamin absorption (fat-soluble vitamins), which would have positive effects on digestive/metabolic processes of other nutrients.

2. Supplemental Dietary Lipids? - Examples in Pigs

A. Baby pigs:

- For nursing piglets, diets mainly consist of sows' milk:
 - 18-20% solids & 6-8% fat (30-40% fat on DM basis).
 - Milk fat droplets are small, i.e., relatively high in short- and medium-chained FA!
 - Highly digestible - Digestibility, 95-100%.
- Weanling pigs:
 - One of the major interests in swine research over the years.
 - Early investigations indicated:
 - Early weaned pigs cannot utilize lipids efficiently.
 - Investigations on a source of fats, emulsifying agents, form of diets (liquid vs dry), etc. had no effect on performance! Examples - Frobish et al., 1969 & 1970. J. Anim. Sci. 29:320 & 30:197.
 - More recent data (based on weekly or daily performance) indicated that pigs are inefficient in utilization of lipids during the first 2 weeks or so after weaning.

Example - Effect of fat source and combinations on starter pig performance: (Li et al., 1990. J. Anim. Sci. 68:3694)

Item	None	Soy	Soy+ Coconut	Coconut	Grease + Grease	coconut
0-2 wk (10% fat)						
ADG, g	281	263	254	272	277	249
ADFI, g ^a	322	286	281	295	304	281
F:G	1.15	1.11	1.13	1.08	1.11	1.14

2-5 wk (5% fat)						
ADG, g ^a	450	490	481	522	490	499
ADFI, g	745	749	717	767	754	722
F:G ^a	1.68	1.52	1.50	1.47	1.55	1.46
0-5 wk						
ADG, g ^{b,c}	400	381	400	390	422	404
ADFI, g ^{c,d}	540	577	563	540	581	577
F:G ^a	1.37	1.52	1.41	1.39	1.37	1.43

^aControl vs. fat ($P < .01$); ^bControl vs. fat ($P = .06$); ^cSoy + coconut vs. coconut ($P < .05$); ^dSoy + coconut vs. grease ($P < .05$).

d) Dried whey/corn oil & lipase activity: (Cera et al., 1990. J. Anim. Sci. 68:384)

Item	Whey, %:	0	0	25	25
	Oil, %:	0	6	0	6
Total lipase units					
7	1,440	1,445	1,787	1,658	
14 ^a	2,575	2,509	3,048	4,082	
21 ^b	7,542	5,577	6,149	5,294	
28 ^b	8,720	11,685	7,991	10,482	
Lipase units/g pancreas					
7	193	196	201	204	
14 200	224	210	255		
21 ^b	328	265	286	267	
28 318	358	335	332		

^aDried whey effect, $P < .01$; ^bOil effect, $P < .05$.

e) Fat sources & apparent digestibility: (Cera et al., 1988; J. Anim. Sci. 66:1430)

Item ^a	Corn oil	Lard	Tallow
Apparent absorption, g/d			
Wk 1 ^b	16.0	13.1	12.0
Wk 2	26.6	25.6	27.6
Wk 3 ^c	47.0	43.8	50.7
Wk 4	63.0	60.7	61.6
Apparent digestibility, %			
Wk 1 ^d	79.0	68.1	64.8
Wk 2 ^d	80.5	71.8	72.4
Wk 3 ^d	88.8	83.6	81.8
Wk 4 ^d	88.8	84.9	82.5

^aLinear response to week, $P < .01$ (all sources); ^bCorn oil vs. animal fats, $P < .01$; ^cLard vs. tallow, $P < .05$; ^dCorn oil vs. animal fats, $P < .05$.

f) Effects of medium- and short-chained fatty acids on apparent digestibility: (Cera et al., 1989. J. Anim. Sci. 67:2040)

Item ^a	Tallow	Corn oil	Coconut oil
Apparent absorption, g/d			
Wk 1	17.7	22.2	18.6
Wk 2	34.7	39.7	38.8
Wk 3	54.0	52.3	64.9
Wk 4	75.8	72.9	77.4
Avg	45.5	46.8	49.9
Apparent digestibility, %			
Wk 1	75.4	76.5	81.7
Wk 2 ^b	76.0	79.7	83.3
Wk 3 ^{c,d}	81.5	86.3	89.2
Wk 4 ^c	86.6	89.3	89.7
Avg ^{c,e}	81.8	84.8	87.3

^aLinear response to week, $P < .01$ (all sources); ^bAnimal vs. vegetable, $P < 0.05$; ^cAnimal vs. vegetable, $P < 0.01$; ^dCorn vs coconut, $P < 0.01$; ^eCorn vs. coconut, $P < 0.01$.

- Also, there were trends for improved weight gain and N utilization (↑ N retention & lower serum urea) with coconut oil.
- The bottom line (baby pigs):
 - a) First two wk or so after weaning, pigs cannot utilize lipids efficiently possibly because of insufficient lipase concentrations or activity.
 - b) The ability of weanling pigs to utilize lipids improves with age.
 - c) Lipids containing higher proportions of short- and medium-chain FA (e.g., coconut oil) may be utilized better by young pigs.

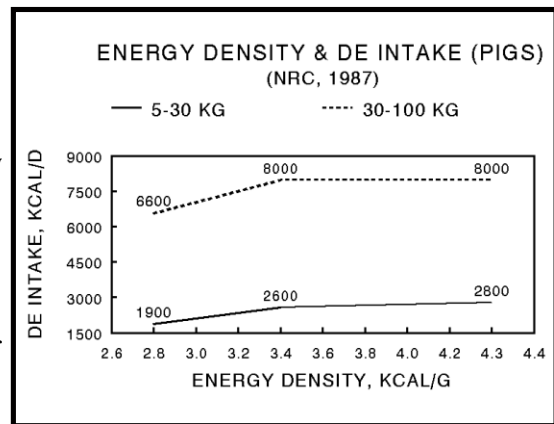

B. Grower-finisher pig:

- 1) The relationship between energy density and feed intake is very important:
 - a) Pigs generally consume feed to meet their energy requirements.
 - b) With reduced energy density, animals increase feed intake.
 - c) With increased energy density, animals reduce feed intake.
 - d) Within a limit, energy intake remains relatively constant:

(1) Energy density and DE intake: See NRC (1987).

(2) Pigs fed graded levels of sand: (Baker et al., 1968. J. Anim. Sci. 27:1332)

Item	% Sand:	0	20	40
------	---------	---	----	----

Gain, kg/d	0.85	0.84	0.73
Feed, kg/d	2.89	3.46	4.13
Feed (- sand), kg/d	2.89	2.77	2.48
G:F	0.294	0.243	0.177
G:F (- sand)	0.294	0.303	0.294

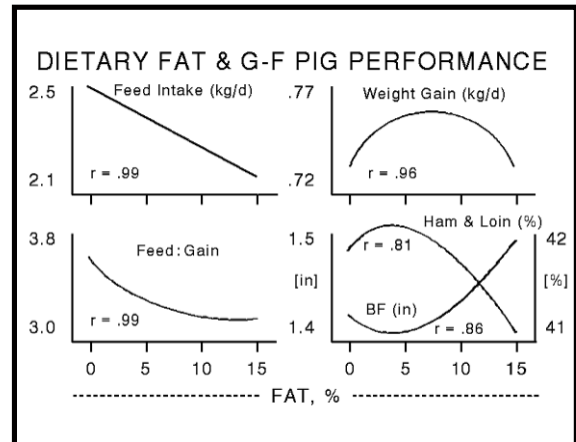
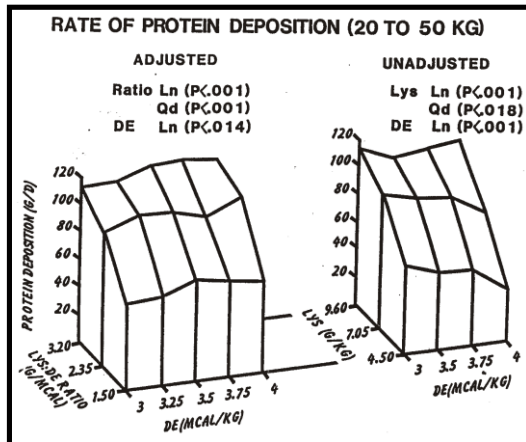

- Because of this relationship, need to balance other nutrients. If not, may see reduced, e.g., protein deposition [Chiba et al. (1991a,b). J. Anim. Sci. 69:694 & 708.]
- Typical responses of growing-finishing pigs to dietary lipids [Moser (1977). Feedstuffs 49(15):20].
- Dietary lipids/thermal environment & relative performance: [Stahly, 1984. In: Wiseman (Ed.)]

Item	Temp (°C):	10			22.5			35		
		Fat (%):	0	5	Δ	0	5	Δ	0	5
ME intake		114	112	-2	100	103	+3	72	77	+5
Gain		99	98	-1	100	109	+9	66	75	+9
ME:gain		116	116	0	100	94	-6	114	106	-8
Backfat		93	97	+4	100	106	+6	85	92	+7

- Utilized better in warm/hot environments than in a cold environment!

- Dietary lipids & apparent digestibility (%): [Stahly, 1984. In: Wiseman (Ed.)]

Item	Fat (%):	Ileal			Fecal		
		4.5	17.0	26.8	4.5	17.0	26.8
CP		74	73	76	82	81	85
Amino acid:							
Lys		83	84	85	83	84	87
Trp		77	79	81	89	89	92
Thr		69	70	73	84	85	88
Met		83	82	84	83	85	86
Avg		78	79	81	87	88	90

- Dietary lipids generally improve digestibility of protein & amino acids!
- The bottom line (grower-finisher pigs):
 - a) To a degree, pigs can adjust feed intake to achieve a constant energy intake.
 - b) Because of this, nutrient levels (especially, amino acids) have to be adjusted in concert with dietary energy densities.
 - c) Dietary lipids - Improve feed efficiency, may or may not improve weight gain, and little adverse effects on carcass with $\approx \leq 5\%$.
 - d) Lipids are utilized better in a warm or hot environment vs cold environment (associated with a low heat production rate in lipid metabolism).
 - e) Dietary lipids may improve nutrient digestibility.

C. Gestating & lactating sows:

- 1) On the average, producers lose about 25-30% of piglets born before weaning (. . . even though there has been some improvement in recent years):
 - a) Most of the losses? - During the first few days & $\approx 1/2$ due to starvation & crushing!
 - b) Smaller, weaker pigs: [Speer, 1970. Unpublished data (based on 1948 litters)]

Birth wt., lb	Survival, %
Under 2.0	42
2.0-2.4	68
2.5-2.9	75
3.0-3.4	82
3.5-3.9	86
4.0 and over	88
Avg	77

- c) Baby pigs:
 - (1) Only $\approx 2\%$ body fat (mostly structural), \therefore low energy reserves.
 - (2) Liver glycogen depletes rapidly within 12-24 h.
 - (3) Develop a hypoglycemia \rightarrow \uparrow chance of being crushed.
 - (4) Little insulation (hair & fat).
 - Because of all these factors (lack of insulation & low energy reserves), pigs cannot maintain a proper body temperature.
- d) To increase survival rate of baby pigs:
 - (1) Must increase body reserves of pigs,
 - (2) Improve the quality of their diet (i.e., milk),
 - (3) And, other management practices.

2) Dietary lipids for sows - Dietary fat can improve the baby pig survival rate!

- a) Summary of effects of dietary fat: [Based on 677-938 litters; Moser & Lewis, 1980. Feedstuffs 52(9):36]

Item	Contr.	Fat	Diff.
Born alive	10.0	9.9	-0.1
No. weaned	8.1	8.4	0.3
Survival, %	82.0	84.6	2.6

- b) The degree of response to dietary lipids depends on the status of herds & birth weight of pigs: (Pettigrew, 1981. J. Anim. Sci. 53:107)

(1) Herds having < 80% survival rate - 4.1 % ↑.

(2) Herds having > 80% survival rate - .6% ↑.

(3) Pigs weighing < 1 kg at birth - 17.1% ↑.

3) Possible reasons for improved baby pig survivability:

- a) Increased fat content of milk - "Effect of dietary fat on milk fat (%)
- ^a
- :"

Item	Fat in diet:	
	-	+
Moser & Lewis, 1980	7.3	9.1
Coffey et al., 1987	5.14	6.07
Schoenherr et al, 1989	5.37	6.85
Newcomb et al., 1991 (DM basis)	20.6	23.6

^aMoser & Lewis. Feedstuffs 52(9):36; Coffey et al. J. Anim. Sci. 65:1249; Schoenherr et al. J. Anim. Sci. 67:482; Newcomb et al. J. Anim. Sci. 69:230.

- b) Increased milk production - "Effect of dietary fat on milk yield (kg/d)
- ^a
- :"

Reference	Contr.	Fat
Kruse et al., 1977	4.60	5.33
Pettigrew, 1978	3.82	4.48
Boyd, 1979	8.72	9.44
Coffey et al., 1987	8.93	11.06

^aKruse et al. Acta Agric. Scand. 27:289; Pettigrew. Proc. Pacific NW Pork Exposition, WSU; Boyd. Ph.D. Dissertation. Univ. of Nebraska; Coffey et al. J. Anim. Sci. 65:1249.

- c) A slight increase in energy reserves of "newborn" piglets
- ^a
- :

Item	Contr.	Fat	
Coffey et al. (1987):			
Blood FFA, mmol/L	3.23	4.12	
Blood TG, mg/dL	31.1	33.9	¶

Newcomb et al. (1991):			
Plasma FFA, $\mu\text{eq/L}$	120.0	136.4	¶
Liver glycogen, % wet tissue	13.9	18.3	¶

^aCoffey et al. J. Anim. Sci. 65:1249; Newcomb et al. J. Anim. Sci. 69:230; ¶ = non significant.

4) Effects of dietary fat at various phases^a: [Moser, 1985. In: Cole & Haresign (Ed.)]

Item	Gestation	Lactation	Gest + Lact
Pigs weaned/sow	+0.7 (3)	+0.7 (2)	0 (17)
Survival (%)	+4.7 (4)	+1.2 (3)	+3.4 (22)

^a(): No. of experiments. Gest + Lact = gestation + lactation.

- a) To observe beneficial effects of fat, sows may have to consume 1 kg of fat before parturition. (Pettigrew, 1981. J. Anim. Sci. 53:107)
- b) Can be done by:
 - (1) Feeding a diet containing 10% fat for a week, or
 - (2) A diet containing 5% fat for 2 weeks before farrowing.

FEED GRADE LIPIDS

- Also, see the composition of some lipid sources in the Section 18!

1. Terminology (See AFIA, 1986. Proc. AFIA 46th Annu. Meeting)

A. Total fatty acids (TFA):

- 1) Include both free FA and those combined with glycerol.
- 2) In general, fats contain \approx 90% FA (9.4 Cal/g) & 10% glycerol (4.2 Cal/g).
- 3) A good index of the potential energy value of fat.

B. Free fatty acids (FFA):

- 1) FA not attached to glycerol.
- 2) High levels of FFA were once thought undesirable:
 - a) High because of extensive bacterial & enzymatic actions, i.e., a reflection of careless handling prior to rendering.
 - b) Also, may be due to \uparrow oxidation rate, \therefore \uparrow rancidity?

- 3) But with the use of antioxidants, high levels pose no problem!

C. Moisture has adverse effects on fat - Corrosion of handling equipment/facilities \rightarrow rust (a powerful promoter of rancidity).

D. Insoluble impurities:

- 1) Include minute particles of fiber, hair, hide, bones, minerals, etc. - insoluble in kerosene or petroleum ether.
- 2) Can cause problems in handling & storage (plus may ↓ nutritional quality).

E. Unsaponifiable matters:

- 1) Include fat soluble vitamins, pigments, sterols, fatty alcohols, etc., which are not split into glycerol and alkali salt of FA (soap) by alkaline hydrolysis (KOH).
- 2) All natural fats & oils contain small amounts.

F. Iodine value:

- 1) Measure the degree of unsaturation (each double bond takes up 2 atoms of iodine).
- 2) Expressed as grams of I absorbed/100 g of oil or fat.

G. Fat stability:

1) Oxidative rancidity:

- a) Can lower the quality of fat.
- b) Can destroy fat-soluble vitamins in feeds.

2) Measured by:

- a) "Peroxide value" - Measures mEq of peroxide/kg lipids, and considered "not" rancid if < 5 mEq/kg.
- b) AOM test:

- (1) A measure of peroxide value after 20 h of bubbling air through samples.
- (2) Determine the ability of fat to resist oxidative rancidity.

H. Titer - An indication of the degree of hardness (or unsaturation):

- 1) Determined by melting FA after fat hydrolysis & cooling slowly, and measuring "congealing" temperature.
- 2) Titer - Over 40°C, classified as "tallow" & under 40°C, classified as "grease."

I. Color:

- 1) Variations - From pure white (refined beef tallow) & yellow color (grease) to very dark color (acidulated soapstock).
- 2) Generally, differences in color have no effect on the nutritional value of fat, but may be an important consideration in "pet" foods.

2. Use of Feed Fats by Various Species (million lb; 1990 = estimates; Rouse, 1987. Feed Management. Feb.):

Animal	1986	1990	% †
Veal	100	125	25
Pet	400	450	13
Hog	100	250	150
Cattle	200	225	13
Broiler	650	750	15
Turkey	500	700	40
Layer	30	50	67
Fish	30	50	67
Dairy	90	250	178
Total	2,100	2,850	35

3. Production of Animal Fats (Rouse Marketing Inc., 1983)

Source	Mil. lb.
Beef tallow	4,387
Restaurant grease	1,350
Pork grease	537
Dead stock	447
Poultry	253
Other	200
Total	7,222

4. Feed Fat Categories

A. "Animal fat:"

- 1) Mainly from packing house offal or supermarket trimmings.
- 2) "Tallow" - Titer = $> 40^{\circ}\text{C}$ & 4-20% FFA:

- a) Fancy - Mainly for pet foods (maximum of 4% FFA).
- b) No. 1 - Maximum of 15% FFA.
- c) No. 2 - Maximum of 20% FFA.

- 3) "Grease" - Titer = $< 40^{\circ}\text{C}$ & 4-50% FFA:

- a) Choice white - Maximum of 4% FFA.
- b) Yellow - Maximum of 15% FFA.
- c) Brown - Maximum of 50% FFA.

- ### B. "Poultry fat" - From poultry offal, and mostly used by the poultry industry as a feed ingredient.

- C. "Blended feed grade animal fats" - A blend of tallow, grease, poultry and restaurant grease.
- D. "Blended animal and vegetable fats" - A blend of animal fats + vegetable fats.
- E. "Feed grade vegetable fat" - Includes vegetable oils, acidulated vegetable soap stock and other refinery by-products.

5. Rancidity - lipids are subject to two types of rancidity:

A. Oxidative rancidity:

- 1) Light, heat & other factors can lead to formation of free radicals in unsaturated fats.
- 2) Free radicals react with oxygen to form peroxides.
- 3) Peroxides react with another unsaturated fat molecule.
... Chain reaction!

- Products? - Ketones, aldehydes, organic acids, etc. - have unpleasant odor/off-flavors!

B. Hydrolytic rancidity:

- 1) At high temperatures (with a presence of water), FA are hydrolyzed from TG (certain minerals can catalyze reactions), which lowers pH of fat.
- 2) Reduces the ME value of lipids.

- "High FFA" concentrations in a "low" grade tallow or grease are clear indication that they have undergone hydrolytic rancidity.

C. Antioxidants - e.g., Ethoxyquin (Santoquin), Butylated hydroxyanisole (BHA), Butylated hydroxytoluene (BHT) . . . , etc.